

SKYJACK™

OPERATING MANUAL

This manual **MUST** be kept and stored with the aerial platform at all times.



SJM & SJII Series

Models 3015, 3219, 3220, 3226, 4620, 4626,
4830, 6826 And 6832

For Service please call **800 275-9522**
Skyjack Inc. Service Center, 3451 Swenson Ave., St. Charles, IL. 60174 FAX 630 262-0006
For Parts in North America and Asia please call **800 965-4626**
Skyjack Inc. Parts Center, 3451 Swenson Ave., St. Charles, IL. 60174 FAX 888 782-4825
For Parts & Service in Europe please call **31 297 255 526**
Skyjack Europe Communicatieweg 29, 3641 SG Mijdrecht Netherlands FAX 31 297 256 948
129916AB-A Printed in Canada August 2007

The Safety Alert Symbol identifies important safety messages on machines, safety signs in manuals or elsewhere. When you see this symbol, be alert to the possibility of personal injury or death. Follow the instructions in the safety message.



This Safety Alert Symbol Means Attention!

Become Alert! Your Safety Is Involved.



DANGER

DANGER indicates an imminently hazardous situation which, if not avoided, will result in death or serious injury.



WARNING

WARNING indicates a potentially hazardous situation which, if not avoided, could result in death or serious injury.



CAUTION

CAUTION indicates a potentially hazardous situation which, if not avoided, may result in minor or moderate injury. It may also be used to alert against unsafe practices.

IMPORTANT

IMPORTANT indicates a procedure(s) essential for safe operation and which, if not followed, may result in a malfunction or damage to the machine.

Table of Contents

Read and Heed	6
Purpose Of Equipment	6
Use Of Equipment	6
Manual	6
Operator	6
Optional Accessories	6
Section 1 - About Your Aerial Platform	
Scope Of This Manual	7
Warranty Statement	7
Warranty Procedures	7
Major Components	9
Major Assemblies	10
Platform	10
Operator's Control Box	10
Manual Storage Box	10
Lifting Mechanism	10
Maintenance Support/Safety Bar	10
Base	10
Lowering Warning System	10
Tilt Sensing System	11
Serial Number Nameplate	11
Standard Features (ANSI, CSA & CE)	12
Optional Equipment (ANSI, CSA & CE)	12
Operator Safety Reminders	13
Electrocution Hazard	13
Safety Precautions	14
Section 2 - Operation	
General	17
Operator Qualifications	17
Operator's Responsibility for Maintenance	17
Maintenance And Inspection Schedule	17
Owner's Inspections	17
Folding Guardrail System	18
Maintenance Support/Safety Bar	18
Lanyard Attachment Rings	19
Tilt Alarm	19
Base Controls	19
Emergency Main Power Disconnect Switch	19
Base Controls	20
Base Control Box	20
Motion Alarm	20
Operator's Control Box - 2 & 3 Speed	21
Operator's Control Box - Proportional	22
Power Extension Deck Control Box	23

Table of Contents

Section 2 - Continued

Parking Brake	23
Free-Wheeling Valve	23
Emergency Lowering System	24
Operating Procedures	24
Set-Up Procedure	24
Raise the Platform	25
Lowering Warning System	26
Pre-start Inspection	26
Operator's Checklist	26
Start And Operation	27
Setting the Base Controls	27
Shutdown Procedure	29
Emergency Lowering Procedure	30
Winching and Towing Procedures	31
Preparation After Winching and Towing	31
Stabilizers	32
Battery Service Procedure	33
Battery Charging Procedure	33
Battery Charger	34-36
Label Locations	44-49

List of Tables

Table 2-1a, 2-1b. Specifications and Features	38-39
Table 2-2. Floor Loading Pressure	40-41
Table 2-3. Owner's Annual Inspection Record	42
Table 2-4. Maximum Platform Capacities (Evenly Distributed)	42
Table 2-5. Maintenance And Inspection Schedule	43

SKYJACK Inc. is continuously improving and expanding product features on its equipment, therefore, specifications and dimensions are subject to change without notice.

Aerial Platform. A mobile device that has an adjustable position platform supported from ground level by a structure.

Purpose Of Equipment

The SKYJACK SJM & SJII series aerial platforms are designed to transport and raise personnel, tools and materials to overhead work areas.

Use Of Equipment

The aerial platform is a highly maneuverable, mobile work station. Lifting and driving **MUST** be on a flat, level, compacted surface.

Manual

The operating manual is considered a fundamental part of the aerial platform. It is a very important way to communicate necessary safety information to users and operators. A complete and legible copy of this manual must be kept in the provided weather resistant storage compartment on the aerial platform at all times.

Operator

The operator **MUST** read and completely understand the safety panel label located on the platform and **ALL** other warnings in this manual and on the aerial platform. Compare the labels on the aerial platform with the labels found within this manual. If any labels are damaged or missing, replace them immediately.

Optional Accessories

The SKYJACK aerial platform is designed to accept a variety of optional accessories. These are listed under "Standard Features and Optional Equipment".

Operating instructions for these options (**If Equipped**) are located in [Section 2](#) of this manual.

For options not listed under "Standard Features and Optional Equipment", contact the SKYJACK service department at **800 275-9522** or fax **630 262-0006**, include the model and serial number for each applicable machine.

1-1. Scope Of This Manual

- a. **This manual** applies to the ANSI/SIA, CSA and CE versions of the SJM & SJII Series aerial platform models listed on (Tables 2-1.)
- **Equipment identified** with “ANSI” meet the ANSI SIA-A92.6-1990 standard.
 - **Equipment identified** with “CSA” meets the CAN3-B354.2&.3-M82 standards.
 - **Equipment identified** with “CE” meets the requirements for the European countries, i.e. Machinery Directive 89/392/EEC, 98/37/EEC and EMC Directive 89/336/EEC and the corresponding EN standards.
- b. **CSA (Canada) and CE (Europe)**
Operators are required to conform to national, state/province and local health and safety regulations applicable to the operation of this aerial platform.
- c. **ANSI/SIA (United States)**
Operators are required by the current ANSI/SIA A92.6 standards to read and understand His/Her RESPONSIBILITIES in the Manual Of Responsibilities before they use or operate this aerial platform.

1-2-a. Warranty Statement

SKYJACK Inc. warrants each new aerial platform to be free of defective parts and workmanship. During the first full year, labor and replacement parts will be provided by the local authorized Skyjack dealer without charge. For the following 48 months, structural components found to be defective will be replaced or repaired at no charge.

A warranty registration card is supplied with each aerial platform. The warranty is only effective when the warranty card has been completed and returned to Skyjack within 15 days of invoiced. When aerial platforms are put into Dealer’s stock, the warranty period does not start until the aerial platform has been shipped to the dealer’s customer. When a unit is put into service and no warranty card has been mailed to Skyjack Inc., the warranty period will commence 15 days from the date the dealer was invoiced for the aerial platform.

All warranty claims are subject to approval by Skyjack’s Service Department. Skyjack Inc. reserves the right to limit or adjust claims with regard to defective parts, labor or travel time based on usual and customary guidelines. Parts purchased from sources other than Skyjack will not be covered under this warranty. Misuse or improper operation, lack of normal maintenance and inspections as outlined in this Operating Manual or the Operating Maintenance and Parts Manual, alterations to original design and/or components or accidents will void all warranty. **Batteries or Engines are not covered by this warranty.**

The above mentioned warranty statement is exclusive and no other warranty whether written, oral or implied shall apply. Skyjack excludes any implied warranty of merchantability and fitness and accepts no liability for consequential damages or for other negligence.

1-2-b. Warranty Procedures

The selling distributor or authorized dealer shall be responsible for the complete handling of customer claims under this warranty. Here is what to do:

1. When a customer files a claim under this warranty, contact Skyjack’s Service Department to verify warranty coverage. NOTE: The complete serial number of the aerial platform is required to verify the claim.

Section 1 - About Your Aerial Platform

1-2-b. Warranty Procedures (Continued)

2. When Skyjack's Service Department verifies warranty coverage, they will also issue an RA (Return Authorization) number for the return of any defective component(s). All items over \$25.00 USD in value must be returned to Skyjack Inc.
3. Fill out a Warranty Claim Form from dealer's supply of claim forms. Then notify Skyjack's Service Department of the warranty claim number on the form used.
4. The distributor/dealer should then file a warranty claim with Skyjack Inc. describing the nature of the defect, probable cause, work performed, travel hours, and labor hours listed separately. Warranty labor will be paid at a rate of (\$42.00 USD) per hour. The travel allowance will be paid at the same hourly rate within the dealers specified territory, limited to a maximum of four (4) hours. If a part has serviceable components, replace the faulty component. For instance, if you have a faulty switch on a controller, please replace the switch. Hydraulic cylinders should be resealed, unless they are damaged beyond repair. Engine failures should be directed to your local engine distributor and covered by the manufacturers warranty. Skyjack will accommodate you and your labor. Labor rates and travel allowances are subject to change without notice.
5. Warranty claims must be received by Skyjack within 15 working days from the date of the repair. Warranty claims received with insufficient information will be returned for correction or completion.
6. Materials returned for warranty inspection must be:
 - a. Carefully packaged to prevent additional damage during shipping.
 - b. Drained of all contents and all open ports capped or plugged.
 - c. Shipped in a container tagged or marked with the RA number.
 - d. Shipped **PREPAID**. Any item(s) returned for warranty by any other means may be refused and returned unless prior approval from Skyjack is obtained.
 - e. Items shipped to the dealer will be sent freight prepaid and added to the invoice.

Failure to comply with the above procedures may delay approval and processing of the warranty claim and could result in the denial of a warranty claim. Skyjack's dealer's accounts must be kept current in order to approve and issue warranty credits. Skyjack reserves the right to withhold issuance of warranty credits to a dealer if their account is not in good standing. This is subject to change without prior notice.

1-3. Major Components

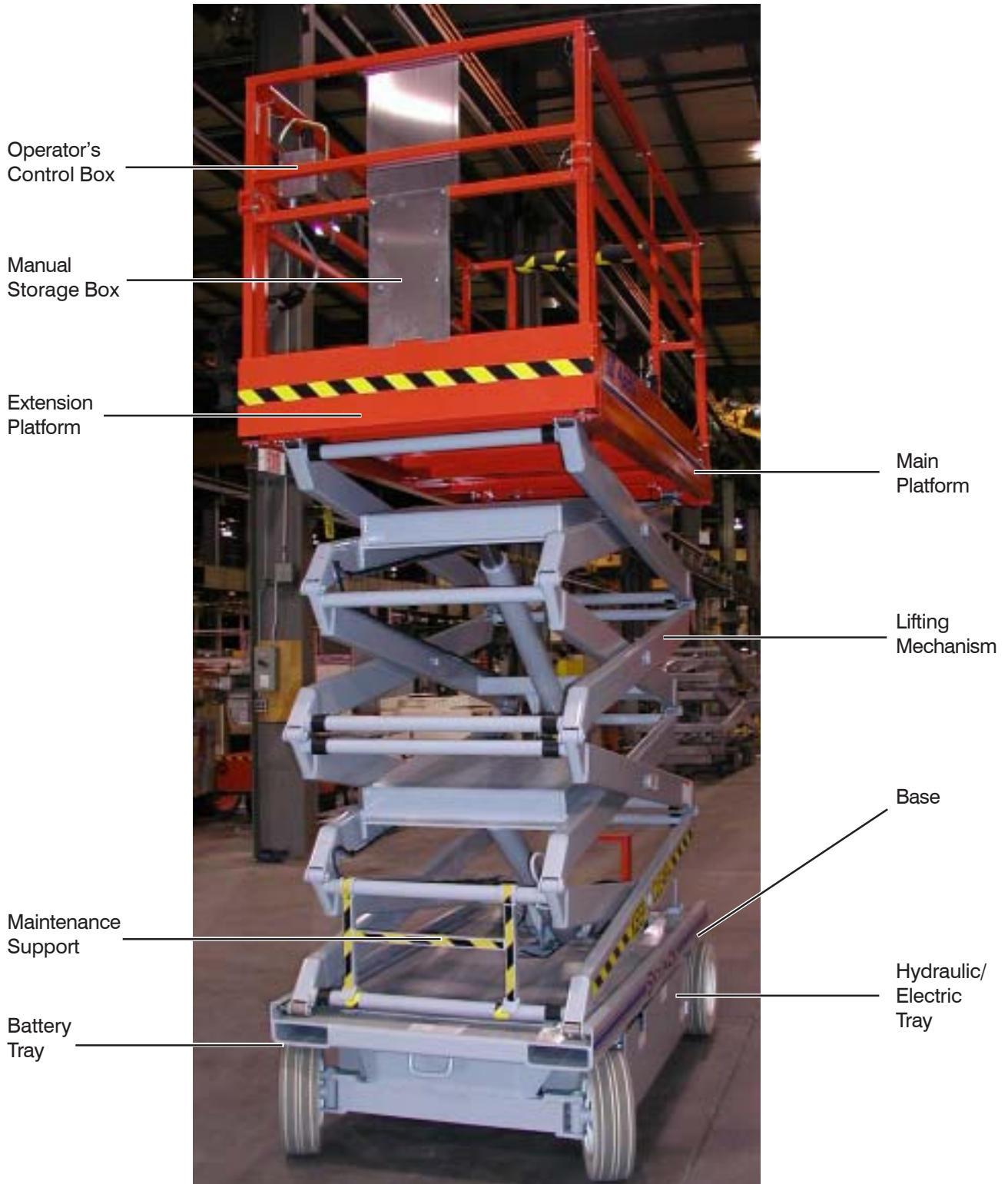

SKYJACK SJM & SJII Series aerial Platform

Section 1 - About Your Aerial Platform

1-4. Major Assemblies

The aerial platform consists of three major assemblies. The platform, lifting mechanism and the base. An operator's control box is mounted on the platform guard-rail. Auxiliary and emergency controls are located at the base.

1-5. Platform

The platform is constructed of a tubular support frame, a skid-resistant "diamond plate" deck surface and 43-1/2" (1100mm) Model 3015 or 41" (1042mm) Model 3219 and 41-1/2" to 43" (1050 - 1100mm) Models 32xx, 46xx, 4830 and 68xx high hinged guardrails with 6" (152mm) toe boards and mid-rails. The platform can be entered from the rear through an entry chain or optional spring-returned gate with latch. The platform is also equipped with an extension platform.

1-6. Operator's Control Box

A removable control box, mounted at the front right of the platform, contains controls for aerial platform motion and emergency stopping.

1-7. Manual Storage Box

This weather resistant box is mounted at the front of the platform. It contains the Operating Manual, the Operating/Maintenance and Parts Manual and other important documentation. The Operating Manual for this make and model of aerial platform MUST remain with the aerial platform and should be stored in this box.



1-8. Lifting Mechanism

The lifting mechanism is constructed of formed steel or tube sections making up a scissor-type assembly. The "scissors" assembly is raised and lowered by one or more single-acting hydraulic lift cylinders with holding valves. A two-section pump, driven by an electric motor, provides hydraulic power to the lift cylinders.

1-9. Maintenance Support/Safety Bar

A Maintenance Support, located inside the lifting mechanism (when properly positioned) can support the scissors and empty platform. The Maintenance Support MUST be used during inspection and maintenance or when repairs are being performed within the lifting mechanism.

1-10. Base

The base is a rigid, one-piece weldment which supports two swing out trays.

- **On Models 3015 and 3219:** One tray contains the hydraulic and electrical components. The other tray contains the battery charger and four (4) 6 volt batteries. The front axle has two hydraulic motor-driven wheels, steerable by a hydraulic cylinder. The rear axle is fixed and has one or two spring-applied hydraulically-released parking brake.
- **On Models 3220, 3226, 4620, 4626, 4830, 6826 and 6832:** One tray contains the hydraulic and electrical components. The other tray contains the battery charger and four (4) 6 volt batteries. The front axle has two non-driven wheels, steerable by a hydraulic cylinder. The rear axle has two hydraulic motor-driven wheels and one or two spring-applied hydraulically-released parking brakes.

1-11. Lowering Warning System (If Equipped)

- **(If Equipped)** - A lowering warning system automatically stops the lowering function before reaching the fully retracted position and sounds an alarm.

1-12. Tilt Sensing System (If Equipped)

The tilt sensing system located on the base of the aerial platform is designed to prevent lifting or driving when the machine is on a slope greater than a predetermined limit. If in this situation the platform must be lowered immediately.

1-13. Serial Number Nameplate

The serial number nameplate, located at the rear of the machine, lists the following:

- Model number
- Serial number
- Machine weight
- Maximum drivable height
- Maximum capacities
- Date manufactured
- Voltage
- System pressure
- Lift pressure
- Maximum platform height
- Maximum wheel load (**Reconditioned Machines**)
- Maximum number of persons permissible on the platform (**Reconditioned Machines**)
- Maximum wind speed (CE only)
- Maximum manual force (CE only)
- Maximum incline (CE only)

Use this information for proper operation and maintenance and when ordering service parts.

Section 1 - About Your Aerial Platform

1-14. Standard Features

- Descent Alarm
- Manual Lowering Valve
- Swing Out Side Trays
- 3 Foot Manual Extension Platform
- Spring-Applied Hydraulically-Released Parking Brake
- Drivable at Full Height (All Models Except 4830)
- 2-Speed Joystick Forward and Reverse Control (Early models)
- Proportional Joystick Forward/Reverse and Lift Control (Later models) (See NOTE)
- Front Wheel Drive With Tight Turning Radius (Models 3015 and 3219)
- Two-Wheel Rear Wheel Series-Parallel Drive (Models 32xx, 46xx, 4830 and 68xx)
- Puncture-Proof Solid Rubber Non-Marking Tires (All Models Except 6826 and 6832)
- Urethane Foam Filled Tires (Models 6826 and 6832)
- Gradability at 20% + (Models 3015 and 3219)
- Gradability at 25% (Models 32xx, 46xx, 4830 and 68xx)

1-15. Optional Features

- Spring-Loaded Full-Height Gate
- Spring-Loaded Half-Height Gate (ANSI only)
- AC Outlet on Platform
- Movement Alarm (CE only)
- Holding Valves on Lift Cylinders
- Flashing Amber Light
- 800W AC Generator
- Additional Parking Brake
- EE-Rating
- Operator Horn
- Tilt Alarm With Lift Cutout (Models 3015 and 3219)
- Shop Air Hose To Platform (Models 3015 and 3219)
- Safety Belt/Lanyard Attachment Rings (Models 3015 and 3219)
- Powered Extension Platform
- Solid Rubber Black Tires (Models 3220, 4620 and 4626)
- Dual Parking Brakes (Standard on 6826, 6832, and Optional on 32xx, 46xx and 4830)
- Elevated Drive Cut-out (Models 32xx, 46xx, 4830 and 68xx)
- Propane/Gasoline or Diesel Engine Package (Models 32xx, 46xx, 4830 and 68xx)

Note: Platform lowering and steering are not proportional.



Warning

Failure to comply with your required responsibilities in the use and operation of the aerial platform could result in death or serious injury!

1-16. Operator Safety Reminders

The National Safety Council reminds us that most accidents are caused by the failure of some individuals to follow simple and fundamental safety rules and precautions. Common sense dictates the use of protective clothing when working on or near machinery. Use appropriate safety devices to protect your eyes, ears, hands, feet and body.

You, as a careful operator, are the best insurance against an accident. Therefore, proper usage of this aerial platform is mandatory. The following pages of this manual should be read and understood completely before operating the aerial platform.

Any modifications from the original design are strictly forbidden without written permission from SKYJACK Inc.

1-17. Electrocution Hazard

This aerial platform is not electrically insulated. Maintain a minimum safe approach distance (MSAD) from energized power lines and parts as listed below. Operator **must allow** for platform sway, rock or sag. **This aerial platform does not provide protection from contact with or proximity to an electrically charged conductor.**

**DO NOT USE THE MACHINE AS A GROUND FOR WELDING.
DO NOT OPERATE THE MACHINE DURING LIGHTNING OR STORMS.**



DANGER

Avoid Power Lines

Minimum Safe Approach Distance

ANSI/SIA A92.6-1999 & CSA CAN3-B354.2&.3-M82 Requirements			CE Guidance Note
Minimum Safe Approach Distance			"Avoidance of danger from Overhead Lines"
Voltage Range (Phase to Phase)	Minimum Safe Approach Distance		These machines should not operate within 15M of overhead lines suspended from steel towers. These machines should not operate within 9M of overhead lines suspended from wooden poles.
	Feet	Meters	
0 To 300V	Avoid Contact		
Over 300V to 50KV	10	3.05	
Over 50KV to 200KV	15	4.60	
Over 200KV to 350KV	20	6.10	
Over 350KV to 500KV	25	7.62	
Over 500KV to 750KV	35	10.67	
Over 750KV to 1000KV	45	13.72	

FAILURE TO AVOID THIS HAZARD WILL RESULT IN DEATH OR SERIOUS INJURY!

60023AC

1-18. Safety Precautions

Know And Understand The Safety Precautions Before Going On To Next Section.



Warning

Failure to heed the following safety precautions could result in tip over, falling, crushing, or other hazards leading to death or serious injury

- **KNOW** all Federal, State, Provincial and local rules which apply to your MACHINE and JOBSITE.
- **DO NOT** leave the aerial platform unattended with the key in the key switch.
- **WEAR** all the protective clothing and personal safety devices issued to you or called for by job conditions.

- **DO NOT** wear loose clothing, dangling neckties, scarves, rings, wristwatches or other jewelry while operating this lift.



- **AVOID** entanglement with ropes, cords or hoses.



- **AVOID** falling. Stay within the boundaries of the guardrails.

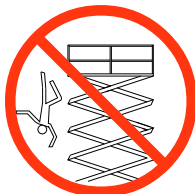

- **DO NOT** raise the aerial platform in windy or gusty conditions.

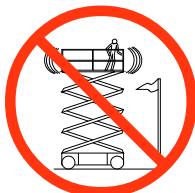

- **DO NOT** increase the lateral surface area of the platform. Increasing the area exposed to the wind will decrease machine stability.



- **DO NOT** drive or elevate the aerial platform if it is not on firm level surfaces. Do not drive elevated near depressions or holes of any type, loading docks, debris, drop-offs and surfaces that may affect the stability of the aerial platform.



- **If Operation In Areas With Holes Or Drop-offs Is Absolutely Necessary**, elevated driving shall not be allowed. Position the aerial platform horizontally only with the platform fully lowered. After ensuring that all 4 wheels or outriggers have contact with level firm surface, the aerial platform can be elevated. After elevation, the drive function must not be activated.



- **Elevated driving** must only be done on a firm level surface.



- **DO NOT** Ascend or descend a grade steeper than 20% (3015 & 3219) or 25% (3220, 3226, 4620, 4626, 4830, 6826 & 6832). Ascend or descend grades only when fully lowered and then only to the maximums noted above.



1-18. Safety Precautions (Continued)

Know And Understand The Safety Precautions Before Going On To Next Section.

- **DO NOT** operate on surfaces not capable of holding the weight of the aerial platform including the rated load, e.g. covers, drains, and trenches.

- **DO NOT** operate an aerial platform that has ladders, scaffolding or other devices mounted on it to increase its size or work height.



- **DO NOT** exert side forces on aerial platform while elevated.



- **DO NOT** use the aerial platform as a crane.



- **DO NOT** sit, stand or climb on the guardrails.



- **DO NOT** climb on scissor arm assembly.

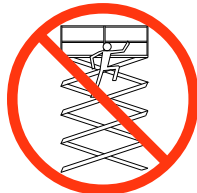

- **BE AWARE** of overhead obstructions or other possible hazards around the aerial platform when driving or lifting.

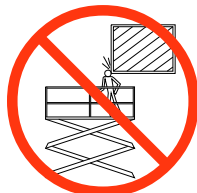

- **DO NOT** raise the aerial platform while the machine is on a truck, fork lift or other device or vehicle.



- **BE AWARE** of crushing hazards. Keep all body parts inside platform guardrail.

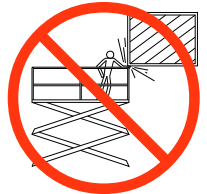

- **DO NOT** lower the platform unless the area below is clear of personnel and obstructions.



- **ENSURE** that there are no personnel or obstructions in the path of travel, including blind spots.



- **BE AWARE** of blind spots when operating the aerial platform.
- **STUNT** driving and horseplay are prohibited.
- **ENSURE ALL** tires are in good condition and lug nuts are properly tightened.
- **DO NOT** alter or disable limit switches or other safety devices.
- **DO NOT** use the aerial platform without guardrails, lock pins and the entry gate/chain/bar in place.
- **DO NOT** exceed the rated capacity of the aerial platform. Do make sure the load is evenly distributed on the platform.

1-18. Safety Precautions (Continued)

Know And Understand The Safety Precautions Before Going On To Next Section.

- **DO NOT** overload the platform, the lift relief valve does not protect against overloading when the platform is elevated.
- **DO NOT** attempt to free a snagged platform with lower controls until personnel are removed from the platform.
- **DO NOT** position the aerial platform against another object to steady the platform.

Jobsite Inspection.

- Do not use in hazardous locations.
- Perform a thorough jobsite inspection prior to operating the aerial platform, to identify potential hazards in your work area.
- Be aware of moving equipment in the area. Take appropriate actions to avoid collision.



Warning

Entering and Exiting the aerial platform should only be done using the 3 point contact system.

- Use only equipped access openings and ladders.
- Enter and exit only when the elevating aerial platform is in the fully retracted position

- **Do Use Three Point Contact To Enter And Exit The Platform.** Enter and exit the platform from the ground only. Face the machine when entering or exiting the platform.
- **Three Point Contact** means that two hands and one foot **OR** one hand and two feet are in contact with the aerial platform at all times during entering and exiting.



Warning

- Do NOT use if work platform is not working
- Do NOT use under the influence of alcohol or drugs
- Do NOT use with damaged tires or wheels.
- Do NOT use with improperly inflated tires.
- Do NOT use with tires or tire fills that are not per manufacturers specifications refer to maintenance manual.



Warning

An operator should not use any aerial platform that :

- Does not have a clean, uncluttered work area.
- Does not appear to be working properly.
- Has been damaged or appears to have worn or missing parts.
- Has alterations or modifications not approved by the manufacturer.
- Has safety devices which have been altered or disabled.

Failure to avoid these hazards could result in death or serious injury.

2-1. General

This section provides the necessary information needed to operate the aerial platform. The following descriptions are for identification, explanation and locating purposes only. It is important that the user reads and understands the proper procedures before operating the aerial platform.

2-2. Operator Qualifications

- **ONLY** trained and authorized personnel **MUST** be permitted to operate an aerial platform.
- Safe use of this aerial platform requires the operator to understand the limitations and warnings, operating procedures and operator’s responsibility for maintenance. Accordingly, the operator **MUST** understand and be familiar with this operating manual, its warnings and instructions, Manual of Responsibilities and **ALL** warnings and instructions on the aerial platform.
- The operator **MUST** be familiar with employer’s work rules and related government regulations and be able to demonstrate their ability to understand and operate **THIS** make and model of aerial platform in the presence of a qualified person.

2-3. Operator’s Responsibility for Maintenance

 Warning
<p>Competent personnel who are familiar with mechanical procedures must perform inspection and maintenance.</p> <p>Death or serious injury could result from the use of an aerial platform that is not properly maintained or kept in good working order.</p>

- The operator must be sure that the aerial platform has been properly maintained and inspected before using it.
- The operator must perform ALL the daily inspections found in “Table 2-5”, even if the operator is not directly responsible for the maintenance of this aerial platform.

2-4. Maintenance And Inspection Schedule

- The inspection points covered in “Table 2-5” indicate the areas of the aerial platform to be maintained or inspected and at what intervals the maintenance and inspections are to be performed.
- The actual operating environment of the aerial platform may affect the maintenance schedule.

 Warning
<p>Use original or equivalent to the original parts and components for the aerial platform.</p>

2-5. Owner’s Inspections

It is the responsibility of the owner to arrange daily, weekly, monthly and annual inspections of the aerial platform. Refer to “Table 2-5” for recommended maintenance and inspection areas and intervals. A record of annual inspection is kept on a label located on the scissors assembly. Refer to “Table 2-3” in this manual.

2-6. Folding Guardrail System

Fold-Down Guardrail System - This system, when folded down, reduces the retracted height of the aerial platform for transporting and traveling through doorways only.

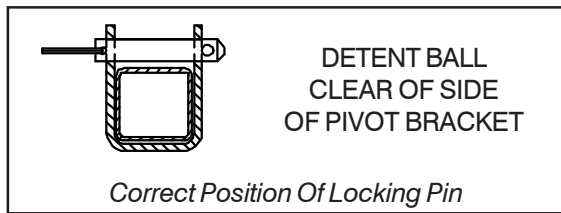
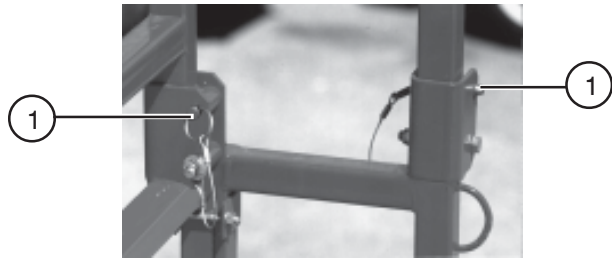

Figure 2-1. Fold-Down Guardrail System

Warning
 The scissors must be fully lowered before raising or lowering the guardrails.

- Guardrail Locking Pin With Lanyard** - To fold the guardrail system down, remove the locking pin at each pivot point and lower each guardrail. To raise the guardrail system, swing up each guardrail and lock in place with the locking pins ensuring that the detent ball of each pin is all the way through and clear of the side of the pivot brackets. (Refer to “Figure 2-1”)

Warning
 Before operating this aerial platform check the guardrail system for loose or missing locking pins. The guardrail system must be upright and all pins must be locked in place. Death or serious injury could result if the guardrail system is not upright or properly locked.

2-7. Maintenance Support/Safety Bar

Maintenance Support - The maintenance support is designed to support the scissors assembly. When properly positioned it can support the scissors and empty platform. The Maintenance Support **MUST** be used when inspection and maintenance or repairs are to be performed within the lifting mechanism.

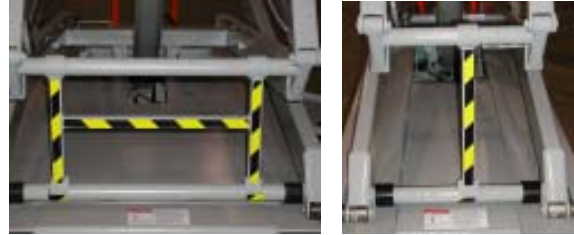

Figure 2-2. Maintenance Support/Safety Bar

Warning
 The maintenance support must be used when inspection and maintenance or repairs are to be performed within the lifting mechanism. Failure to use this safety mechanism could result in death or serious injury.

Proper Use Of Maintenance Support/Safety Bar

- Remove all material from platform.
- Raise platform until there is adequate clearance to swing down the maintenance support.
- Swing maintenance support down from storage bracket into a vertical position.
- Remove hands and arms from scissors area.
- Lower platform until bottom end of maintenance support contacts the labeled cross bar and scissors are supported by maintenance support.
- Turn off Emergency Main Power Disconnect Switch.

To Return The Maintenance Support/Safety Bar

- Turn on Emergency Main Power Disconnect Switch.
- Raise platform until there is adequate clearance to swing up the maintenance support.
- Swing bar up into storage bracket.
- Lower platform.



Warning

Do not reach through the scissors assembly when the platform is raised without the maintenance support properly positioned. Failure to avoid this hazard will result in death or serious injury.

2-8. Lanyard Attachment Ring (If Equipped)

Lanyard Attachment Ring - Use this ring as an attachment point for safety belt/harness tethers. DO NOT attach belts/harnesses to any other point on the platform. DO NOT use this ring to lift, anchor, secure or support the platform or any other apparatus or material.



1

Figure 2-3. Lanyard Attachment Ring



Warning

The lanyard attachment ring is used for travel restraint, within the limits of the platform only. It is not a fall arresting device! Use as such could result in death or serious injury.

2-9. Tilt Alarm (If Equipped)

- The aerial platform is equipped with a device, which senses when the machine is out of level in any direction. When activated, it prevents Drive and Lift functions of the aerial platform and an alarm produces an audible sound accompanied by the amber light (If Equipped). These alarms activate once every 1.5 seconds. Lower platform completely, then reposition machine so that it is level before raising platform.

2-10. Base Controls

2-10-a. Emergency Main Power Disconnect Switch

Emergency Main Power Disconnect Switch - This Switch is located at the rear of the base (fig. 2-4a) or the rear of the Hydraulic/Electric Tray (fig. 2-4b).



Figure 2-4a. SJM Series - Main Power Disconnect Switch

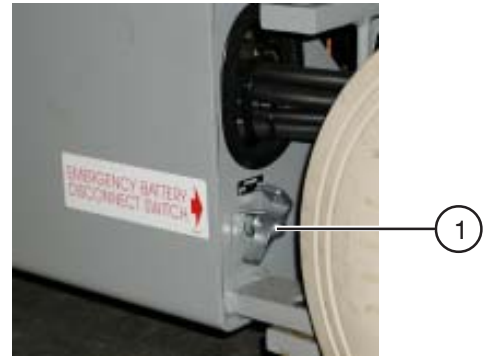

Figure 2-4b. SJII Series - Main Power Disconnect Switch

- Emergency Main Power Disconnect Switch** - This Switch, when in “OFF” position, disconnects power to all circuits. Switch MUST be in “ON” position to operate any circuit.

Section 2 - Operation

2-10-b. Base Controls

This control station is located in the Hydraulic/Electric tray. It contains the following controls:



Figure 2-5. SJM Series Electrical Panel

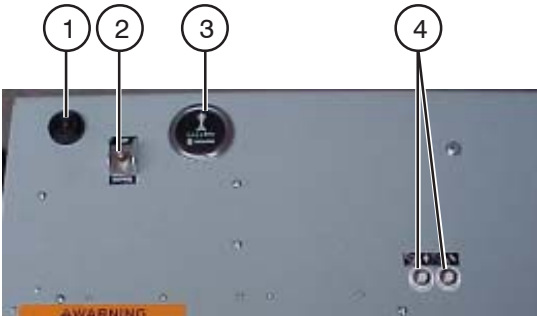

Figure 2-5b. SJII Series Electrical Panel

1. **Buzzer Alarm** - This audible pulse alarm will beep in varying intervals depending on the status of the platform.
2. **Platform Up/Down Toggle Switch** - This toggle type switch raises or lowers the platform to a desired height.
3. **Hourmeter** - This gauge records the accumulated time of operation of the aerial platform.
4. **Circuit Breaker Resets** - In the event of a power overload or positive circuit grounding, the circuit breaker will pop out.

2-10-c. Base Control Box (If Equipped)

This control station is found on the rear of the base. It contains the following controls:

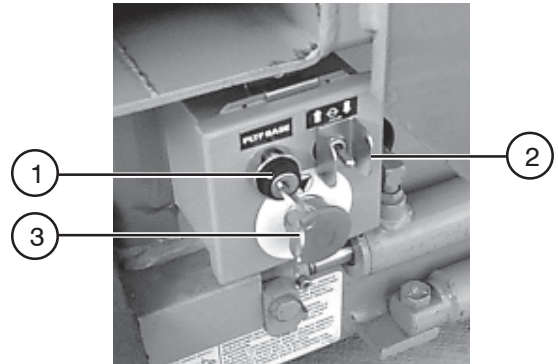

Figure 2-6. Base Control Box

1. **Platform/Base Select Key Switch** - Key to “PLATFORM” position directs power to the operator’s control box on the platform. Key to “BASE” position directs power to the base control box.
2. **Platform Up/Down Toggle Switch** - This toggle type switch raises or lowers the platform to a desired height. To raise the platform, key to “BASE” position, then move switch to “↑” (up) position. Release switch to stop. To lower the platform, key to “BASE” position, then move switch to “↓” (down) position. Release switch to stop.
3. **Emergency Stop Button** - When depressed, this red “mushroom-head” push-button switch disconnects power to the control circuit.

2-11. Motion Alarm (If Equipped)

- The aerial platform is equipped with a motion alarm. The alarm produces an audible sound at a rate of about once every two seconds when any control function is selected. On machines with certain options, a flashing amber light will accompany this alarm.

2-12. Operator's Control Box: 2 Speed and Optional 3 Speed

Operator's Control Box - This metal control station is mounted at the right front of the platform. It contains the following controls:

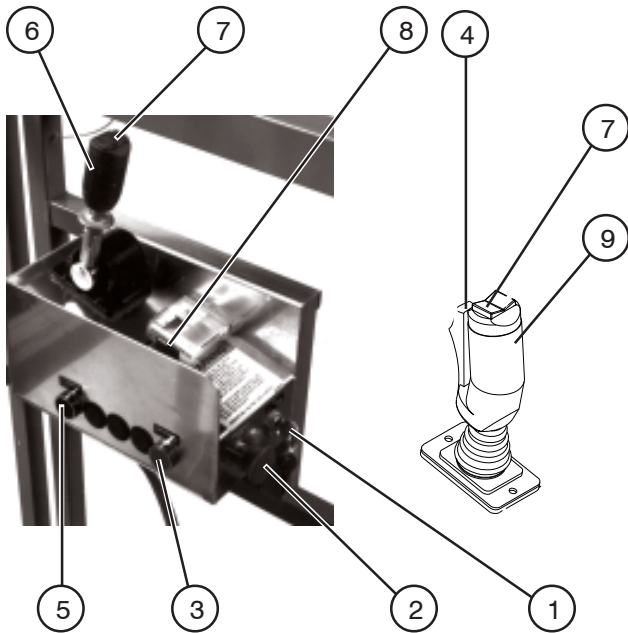

Figure 2-7. Operator's Control Box

1. **Lift/Off/Drive Select Key Switch** - Key to "LIFT" position energizes the lift circuit. Key to "OFF" position disconnects power to control circuit in the control box. Key to "DRIVE" position energizes the drive/steer circuit.
2. **Emergency Stop Button** - When depressed, this red "mushroom-head" push-button switch disconnects power to the control circuit.
3. **Lift Enable Push-button (If Equipped)** - When depressed and held, this push-button switch energizes the lift circuit. It MUST be depressed and held while raising or lowering the platform from this control station. Release button to stop.
4. **Drive Enable Switch (If Equipped)** - This momentary "Trigger" style switch energizes the controller. It must be held depressed continuously while engaging either the drive or steer functions.
5. **Operator Horn Push-Button** - Located on the side of the Operator's Control Box, this push-button switch, when depressed, sounds an automotive-type horn.
6. **Drive/Steer Controller (If Equipped)** - This one-handed toggle-type lever controls two-speed drive and left/right steer motion. Internal springs return it to neutral and lock it when stick is released. To unlock lift lock ring and push or pull according to desired task.
7. **Steering Rocker Switch** - This rocker style switch on the top of the controller handle controls the direction the machine travels.
8. **Up/Down Selector Switch** - This switch when used with the Lift Enable Push button can lift or lower the platform to a desired height.
9. **Drive/Steer Controller (If Equipped)** - This one-handed toggle-type lever controls two-speed drive and left/right steer motion. Internal springs return it to neutral when stick is released.

**2-13. Operator's Control Box:
Proportional Controller**

Operator's Control Box - This metal control station is mounted at the right front of the platform. It contains the following controls:

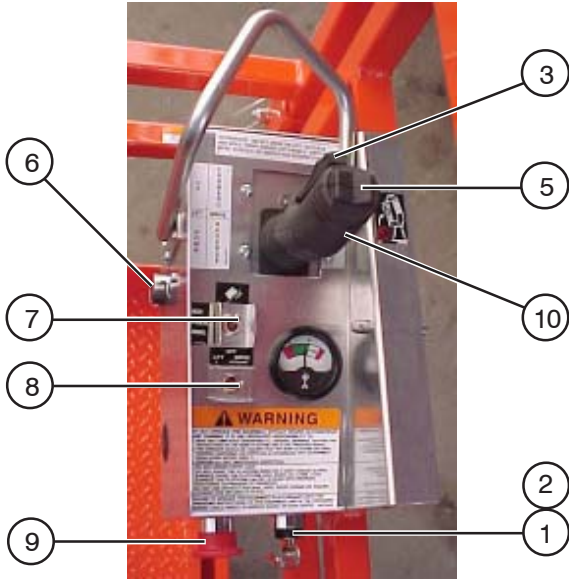

Figure 2-8a. Operator's Control Box

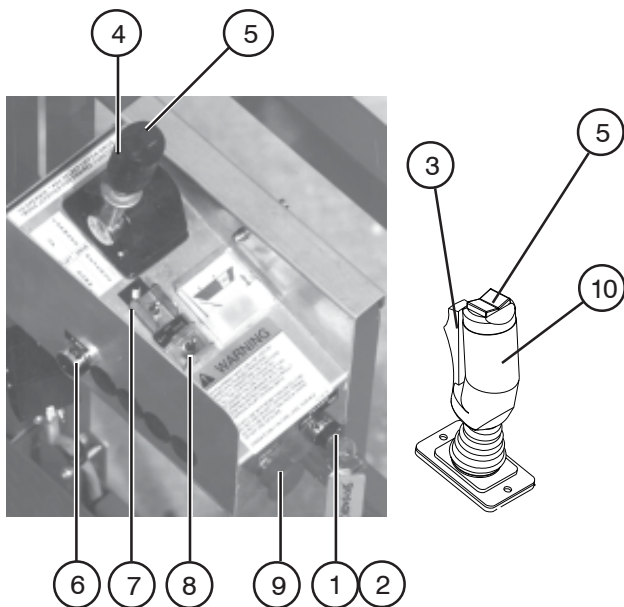

Figure 2-8b. Operator's Control Box

1. **Off/On Key Switch (ANSI and CSA)**-Disconnects or energizes the control circuit in the operator's control box.
2. **Platform/Off/Base Select Key Switch (CE)** - This three-way selector switch allows the operator to turn off the power to the aerial platform or to activate either the base or platform controls.
3. **Lift/Drive Enable Switch (If Equipped)** - This momentary "Trigger" style switch (on later models) energizes the proportional controller. It must be held depressed continuously while engaging either the drive/lift or steer functions.
4. **Drive/Steer Controller (If Equipped)** - This one-handed toggle-type lever controls drive/lift motion. Internal springs return it to neutral and lock it when stick is released. To unlock lift lock ring and push or pull according to desired task.
5. **Steering Rocker Switch** - This rocker style switch on the top of the controller handle controls the direction the machine travels.
6. **Operator Horn Push-Button** - Located on the side of the Operator's Control Box, this push-button switch, when depressed, sounds an automotive-type horn.
7. **High/Normal Torque Select Toggle Switch (If Equipped)** - This switch selects "HIGH" torque (low speed) or "NORMAL" torque (high speed). (Models 3220, 3226, 4620, 4626, 4830, 6826 & 6832 only)
8. **Lift/Off/Drive Select Toggle Switch** - If "Lift" is selected, the lift circuit is energized. "OFF" disconnects power from both the lift and drive circuits. If "DRIVE" is selected, the drive circuit is energized.
9. **Emergency Stop Button** - When depressed, this red "mushroom-head" push-button switch disconnects power to the control circuit.
10. **Drive/Steer Controller (If Equipped)** - This one-handed toggle-type lever controls drive/lift motion. Internal springs return it to neutral when stick is released.

2-14. Powered Extension Deck Control Box (If Equipped)

This metal control box is mounted on the extension platform guard rail. It contains the following controls:

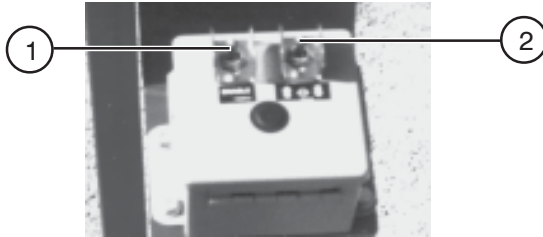

Figure 2-9. Powered Extension Deck Control Box

1. **Enable Switch** - This switch, when activated and held allows the Extension Deck Extend/Retract Switch functions to operate.
2. **Extend/Retract Switch** - This switch, when activated, extends or retracts the powered extension deck.

2-15. Parking Brake

Parking Brake - The parking brakes are devices that are always mechanically engaged until hydraulically or manually released.

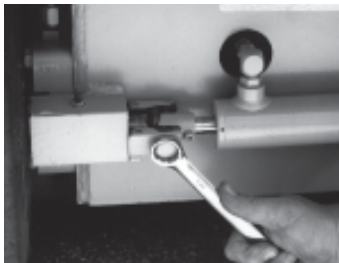

Figure 2-10. Parking Brake

A pin retracted by a single-acting hydraulic cylinder disengages each brake disc when driving. Remove the Cotter Pin and Stabilizer Lock Pin and fully extend each stabilizer. A spring inside each cylinder returns the pin to engage the brake disc for parking, lifting, lowering and stationary steering. The brake pin **MUST** be manually disengaged for towing, pushing or winching.

Note

Refer to “[section 2-26](#)” For Winching and Towing procedure.

2-16. Free-Wheeling Valve

Free-Wheeling Valve - The free-wheeling valve is located at the front and/or rear of the machine. (depending on model)



Figure 2-11a. Free-Wheeling Valve (SJM Series)



Figure 2-11b. Free-Wheeling Valve (SJII Series)

1. **Free-Wheeling Valve** - Turning the valve knob (counterclockwise) to a fully opened position allows fluid to flow through the wheel motors, thus providing “free-wheeling” so that the aerial platform can be pushed, towed or winched after the brakes are released without damaging the wheel motors. The Free-wheeling valve **MUST** be closed tightly (clockwise) for normal operation.

Note

Refer to “[section 2-26](#)” For Winching and Towing procedure.

2-17-a. Emergency Lowering System (Machines with Holding Valves)

Emergency Lowering System - This system allows platform lowering in the event of an emergency or an electrical system failure.



Figure 2-12a. Emergency Lowering System

1. **Emergency Lowering Valve** - Located at the front of the hydraulic/electric tray (item 1), this pull-type valve when used in conjunction with the holding valve manual overrides, allows platform lowering in the event of an emergency or electrical system failure.
2. **Holding Valve Manual Override Knob** - Located on the holding valve at the bottom of each lift cylinder (item 2), these red knobs when depressed and turned counterclockwise allow hydraulic oil to bypass each holding valve. The red knobs on each holding valve **MUST** be depressed and turned clockwise to restore normal operation.



Warning

Before operating this aerial platform check the guardrail system for loose or missing locking pins. The guardrail system must be upright and all pins must be locked in place. Death or serious injury could result if the guardrail system is not upright or properly locked.

2-17-b. Hydraulic (Machines with Velocity Fuses)

Emergency Lowering Valve (Rotary-type) - Located in the hydraulic/electric tray, this valve allows platform lowering in the event of an electrical system failure.



Figure 2-12b. Emergency Lowering Valve

1. **Emergency Lowering Valve (Rotary-type)** - Turning the valve knob counterclockwise allows the platform to gradually lower. Valve **MUST** be fully closed (clockwise) to restore normal operation.



Warning

Keep clear of scissor mechanism when using emergency lowering valve.

Refer to “[section 2-25](#)” For Emergency Lowering

Operating Procedures

The following are descriptions of normal operating procedures. A qualified operator **MUST** read and completely understand these descriptions before operating this aerial platform.

2-18. Set-Up Procedure



1. Remove all packing materials and inspect for damage incurred during transport. This step is normally only required after the equipment has been unloaded and is being put into service for the first time. Report any damage to delivery carrier immediately.
2. Inspect aerial platform thoroughly and remove any foreign objects.
3. Raise all guardrails to their upright position and lock in place with locking pins. (Refer to “[figure 2-1](#)”)

4. Ensure the Emergency Main Power Disconnect Switch is switched to the "OFF" position. Remove the operator's control box from its shipping container and secure it to the guardrail at the right front of the platform. Attach the control cable and power extension deck cable (**If Equipped**) to the machine's control cable.
5. Move the aerial platform to a firm, level test area where the platform can be later vertically extended to its maximum working height. If the aerial platform is to be pushed, towed or winched, Refer to "section 2-26" for the proper guidelines for "Winching and towing procedures."
6. Unlock and swing out the hydraulic/electric tray and battery tray.
7. In the hydraulic/electric tray, check the tank's hydraulic oil level (scissors must be fully lowered). Level should be at or slightly above the top mark on the sight glass. Close the hydraulic/electric tray.

Note

If required, add a quality grade hydraulic oil such as ATF Dexron III (ESSO). Never mix hydraulic oils.

For conditions below 32°F(0°C), an oil with a viscosity range of 135-165SUS @ 100°F(40°C) (ISO Grade 32) is recommended. For conditions above 32°F(0°C), an oil with a viscosity range of 284-346SUS @ 100°F(40°C) (ISO Grade 68) is recommended.

 Warning
<p>Explosion Hazard Keep flames and sparks away. Do not smoke near batteries.</p> 

 Warning
<p>Battery Acid Is Extremely Corrosive Wear proper eye and facial protection as well as appropriate protective clothing. If contact occurs, immediately flush with cold water and seek medical attention.</p>

8. In the battery tray, check the battery fluid level. If fluid level is not at FULL mark on battery, add distilled or demineralized water only.

9. Connect the A.C. battery charger cord to the proper A.C. voltage source and charge the batteries. (Refer to "section 2-30" for "Battery Charging Procedures"). When charger cycle is complete, disconnect battery charger A.C. cord.

2-19. Raise The Platform

1. Turn the Emergency Main Power Disconnect Switch to "ON" position.

 Warning
<p>Be aware of overhead obstructions or other possible hazards around the machine when lifting.</p>

2. Ensure the emergency stop buttons on the base control box (**If Equipped**) and the operator's console box are pulled out.
3. Raise the platform with Up/Down Toggle Switch from the hydraulic tray, or base control box (**If Equipped**) until there is an adequate clearance to swing down the maintenance support.
4. Lift the maintenance support from the storage channel and swing down into position. (Refer to "section 2-7" for proper procedure.) Lower the platform until the scissor assembly is firmly supported by the maintenance support.
5. Inspect all hoses, fittings, wires, cables, valves, etc. for leaks, hidden damage and foreign material.
6. Raise the platform until there is an adequate clearance to swing up maintenance support. Return the maintenance support to storage channel.
7. Raise the platform to the maximum extension height.

 Warning
<p>To protect against unintended movement of the aerial platform, push in the emergency stop button after you have arrived at your desired location or elevation.</p>

8. Fully lower the platform.

Section 2 - Operation

2-20. Lowering Warning System (If Equipped)

A lowering warning system automatically stops the lowering function before reaching the fully retracted position and sounds an alarm. After the operator has released the down controls and taken time to check that no person is near the scissors, the lowering function can be reactivated.

2-21. Pre-start Inspection

It is the responsibility of the operator to perform a Pre-start inspection.

The pre-start inspection is a visual inspection performed by the operator prior to each work shift.

1. Carefully read and completely understand ALL of Section 2, OPERATION in this manual and ALL warnings and instruction labels on the aerial platform.
2. Ensure that there are no obstacles around the aerial platform and in the path of travel such as holes, drop offs, debris, ditches and soft fill.
3. Ensure that there are no electrical cords and hoses with a diameter of more than 1/2" in the path of travel.
4. Ensure that the batteries are fully charged. Disconnect the AC charger cord from the external power source.
5. Ensure that both side battery and hydraulic trays are closed and locked.
6. Ensure that the Free-Wheeling Valve is fully closed.
7. Make sure all guardrails and lock pins are in place and locked in position.
8. Make sure you do not climb or descend a grade steeper than 20% (3015 & 3219) or 25% (32xx, 46xx, 4830 & 68xx). Elevated driving must only be done on firm level surfaces.
9. Check overhead clearances.



Warning

Do not use or operate the aerial platform if any component appears to be altered, damaged or if it is tagged or locked out for non-use or repair. Operation of aerial platform while in any of the above states may result in death or serious injury

2-22. Operators Checklist

It is the users responsibility to inspect the machine operation before the start of each shift:

1. Operating and Emergency controls.
2. Safety devices and limit switches.
3. Personal protective devices.
4. Tires and wheels.
5. Outriggers (**If Equipped**) and other structures.
6. Air, hydraulic and fuel system(s) for leaks.
7. Loose or missing parts.
8. Cables and wiring harnesses.
9. Placards, warnings, control markings and operating manuals.
10. Guardrail system including locking pins.
11. Engine oil level (**If Equipped**).
12. Battery fluid level.
13. Hydraulic reservoir level.
14. Coolant level (**If Equipped**).
15. Parking brake (Check operation).



Warning

Do not operate this aerial platform without proper authorization and training. Failure to avoid this hazard could result in death or serious injury.

Start And Operation:



Warning

An operator should not use any aerial platform

That:

- Does not appear to be working properly.
- Has been damaged or appears to have worn or missing parts.
- Has alterations or modifications not approved by the manufacturer.
- Has safety devices which have been altered or disabled.

Failure to avoid these hazards could result in death or serious injury.

2-23. Setting the Base Controls:

1. Turn the Emergency Main Power Disconnect Switch to “ON” position.
2. At the base control box, pull out Emergency Stop Button **(If Equipped)**.

Using the controls on the platform:

- Use the ladder of the aerial platform to access the aerial platform deck. Close and latch the chain/gate.



Warning

To protect against unintended movement of the aerial platform, push in the emergency stop button after you have arrived at your desired location or elevation.

3. To Raise the Platform:



Warning

Be aware of overhead obstructions or other possible hazards around the machine when lifting.

- At the main control box, pull out the Emergency Stop Button.

3a. 2 or 3 Speed Control:

- Select “LIFT” position with Lift/Off/Drive Select Key Switch.
- Depress and hold the Lift Enable Push-button.
- Then rotate selector switch to “↑” (up) position.
- Release switch to stop.

3b. Proportional Control:

- Select “ON” position with On/Off Select Key Switch or select “PLATFORM” position with Platform/Off/Base Select Key Switch **(If Equipped)**.
- Select “LIFT” position with the Lift/Off/Drive Toggle Switch.
- **Earlier Controller:** Lift the controller lock ring and push handle forward until desired height is reached. Release handle to stop.
- **Later Controller:** Activate and hold the Enable trigger switch (by squeezing it towards the joystick). Push the controller handle forward until desired height is reached. Return the joystick to the neutral center position to stop.



Warning

If the tilt alarm sounds and the platform does not, or only partially raises, immediately lower the platform and ensure that the machine is on a firm **LEVEL** surface.

Important Note

Machines equipped with stabilizers have a 20 foot cutout lift function. Refer to “[section 2-28](#)” for procedures on “Stabilizers”.

Section 2 - Operation

4. To Lower the Platform:



Warning

Do not lower the platform unless the area below is clear of personnel and obstructions.

- At the main control box, pull out the Emergency Stop Button.

4a. 2 or 3 Speed Control:

- Select "LIFT" position with Lift/Off/Drive Select Key Switch.
- Depress and hold the Lift Enable Push-button.
- Then rotate selector switch to "↓" (down) position.
- Release switch to stop.

4b. Proportional Control:

- Select "ON" position with On/Off Select Key Switch or select "PLATFORM" position with Platform/Off/Base Select Key Switch (**If Equipped**).
- Select "LIFT" position with the Lift/Off/Drive Toggle Switch.
- **Earlier Controller:** Lift the controller lock ring and pull handle backward until desired height is reached. Release handle to stop. NOTE: Platform lowering is not proportional.
- **Later Controller:** Activate and hold the Enable trigger switch (by squeezing it towards the joystick). Pull the controller handle backward until desired height is reached. Return the joystick to the neutral center position to stop.



Warning

To protect against unintended movement of the aerial platform, push in the emergency stop button after you have arrived at your desired location or elevation.

5. To Drive/Steer:



Warning

- Limit travel speed according to conditions.
- Be aware of blind spots when operating the aerial platform.

- At the main control box, pull out the Emergency Stop Button.

5a. 2 or 3 Speed Control:

- Select "DRIVE" position with Lift/Off/Drive Select Key Switch.
- Activate and hold the Enable trigger switch by squeezing it towards the joystick, or lift the controller lock ring (on earlier models).
- Push or pull the controller handle forward or backward to the desired speed and direction of platform travel.
- Return the joystick to the neutral center position to stop. Release the Enable trigger switch.

To Steer:

- Select "DRIVE" position with Lift/Off/Drive Select Key Switch.
- Activate and hold the Enable trigger switch by squeezing it towards the joystick (**If Equipped**).
- Press the rocker on top of the controller handle in the direction you wish to steer.

5b. Proportional Control:

- Select "ON" position with On/Off Select Key Switch or select "PLATFORM" position with Platform/Off/Base Select Key Switch (**If Equipped**).
- Select "DRIVE" position with the Lift/Off/Drive Toggle Switch.
- Activate and hold the Enable trigger switch by squeezing it towards the joystick, or lift the controller lock ring (on earlier models).

- Push or pull the controller handle forward or backward to the desired speed and direction of platform travel.
- Return the joystick to the neutral center position to stop. Release the Enable trigger switch.

To Steer:

- Select “ON” position with On/Off Select Key Switch or select “PLATFORM” position with Platform/Off/Base Select Key Switch **(If Equipped)**.
- Activate and hold the Enable trigger switch (by squeezing it towards the joystick) **(If Equipped)**.
- Press the rocker on top of the controller handle in the direction you wish to steer.

 Warning
<p>If the machine does not drive when elevated</p> <ul style="list-style-type: none"> • Disengage the drive controller. • Lower the platform immediately. • Ensure the machine is being operated on a compacted, firm level surface or the tilt sensor will disable some or all functions.

6. To Sound the Horn:

Depress the horn push-button located on the side of the operator’s platform control box.

7. To Extend/Retract a manual extension deck:

 Warning
<p>Ensure that there are no personnel or obstructions in the path of travel, including blind spots</p>

Remove the locking pin(s) and push/pull the extension deck using the sliding handrails or push-bar. Reinsert the locking pin(s), upon full retraction or extension to prevent accidental movement of the manual extension platform during travel or transport.

8. To Extend/Retract powered extension deck:

Ensure the emergency stop buttons on the base control box **(If Equipped)** and the operator’s console box are pulled out. Turn key to Lift position with Lift/Off/Drive Select Switch. On the powered extension deck control box, activate the Enable Switch **(If Equipped)**, then push the extension/retraction toggle switch to the “↑” (extend) position until desired extension is reached. Release switch to stop.

To retract the platform, ensure the emergency stop button is pulled out and turn key to Lift position with Lift/Off/Drive Select Switch. On the powered extension deck control box, activate the Enable Switch **(If Equipped)**, then push the extension/retraction toggle switch to the “↓” (retract) position until desired extension is reached. Release switch to stop.

Note

On machines manufactured 3/96 and since, the extension platform **MUST** be retracted to 3 ft. extension or less before driving. On machines manufactured 2/96 and prior, the extension platform **MUST** be fully retracted before driving. On machines equipped with scissor guards, the extension platform **MUST** be fully retracted to fully lower the platform.

 Warning
<p>To protect against unintended movement of the aerial platform, push in the emergency stop button after you have arrived at your desired location or elevation.</p>

2-24. Shutdown Procedure

1. Completely lower the platform.
2. Turn Key Switch to “OFF” position. Remove key.
3. Push Emergency Stop Button(s) in.
4. Rotate Emergency Main Power Disconnect Switch to “OFF” position.
5. Push in Emergency Stop Button located on Base Control Box **(If Equipped)**.

2-25 Emergency Lowering Procedure

Emergency Lowering System - This system allows platform lowering in the event of an emergency or an electrical system failure.



Figure 2-13a. Emergency Lowering System

1. Turn Emergency Main Power Disconnect Switch to “OFF” position.
- 2a. For machines equipped with Holding Valves, depress and turn each red manual override knob (Item 2) counterclockwise.
- 2b. For machines without Holding Valves, proceed to next step.

3. Pull the Emergency Lowering Valve knob (Item 2), or turn the rotary-type valve (Item 3) counterclockwise to gradually lower the platform.
4. Turn each red manual override knob, or Emergency Lowering Rotary-Valve clockwise to restore normal operation.

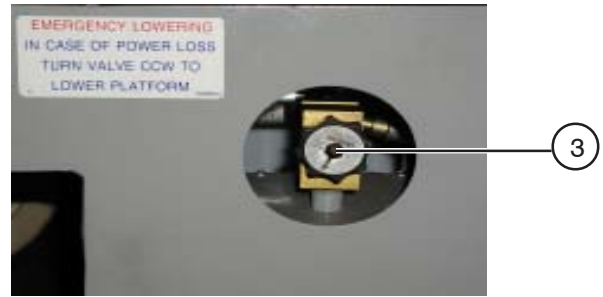

Figure 2-13b. Emergency Lowering Rotary-Valve

 Warning
Keep clear of scissors mechanism when using emergency lowering valve.

2-26. Winching And Towing Procedures



Warning

Ensure platform is fully lowered before winching or towing. Sudden motion could cause the aerial platform to become unstable. Death or serious injury could result.



Warning

When pushing, towing or winching, Do not exceed 2 mph (3.2 km/h).



Warning

Do not push, tow or winch either vehicle on to a slope, or brake the towing vehicle rapidly. Do not pull the aerial platform down an incline towards a winch.



Warning

Do not manually disengage the parking brakes if the aerial platform is on a slope.

Make sure that the aerial platform is on level ground.

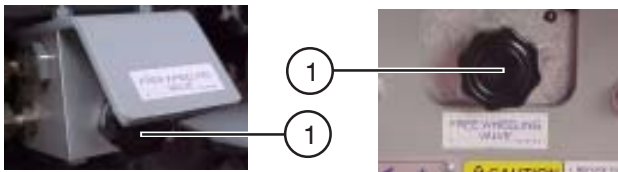

Figure 2-14. Free-Wheeling Valves
SJM (left)/SJII (right)

1. Chock or block the wheels to keep aerial platform from rolling.
2. **Free-Wheeling Valve** - Turning the valve knob (counterclockwise) to a fully opened position allows fluid to flow through the wheel motors, thus providing “free-wheeling”.

3. **Parking Brake** - The brake pins MUST be manually disengaged for pushing, towing or winching.

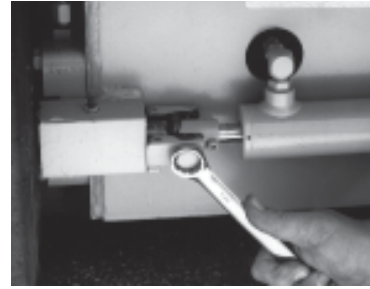

Figure 2-15. Parking Brake

- **For Left-Hand Brake:** Using a 3/4" wrench, rotate the lock-out block on the brake pin 90° clockwise. The brake pin should be clear of the brake disc.
- **For Right-Hand Brake:** Using a 3/4" wrench, rotate the lock-out block on the brake pin 90° counterclockwise. The brake pin should be clear of the brake disc.

Note

The parking brakes will reset automatically when the work platform is driven.

2-27. Preparation After Winching Or Towing

- Position machine on a firm, level surface.
- Chock or block the wheels to keep aerial platform from rolling.
- Engage the parking brake by momentarily activating the drive function.
- Close free-wheeling valve.

Note

The SJM & SJII Series aerial platforms are now ready for use by an authorized, qualified operator who has read and completely understands ALL of [Section 2, OPERATION](#) in this manual.

Section 2 - Operation

2-28. Stabilizers (Model 3226 only)

STABILIZERS - Stabilizers are located at each of the four corners of the base. To use the stabilizers follow the procedure below:

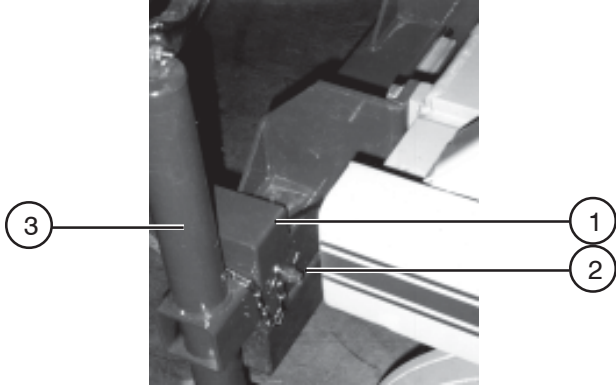

Figure 2-16. Stabilizer

1. **Stabilizer Lock Pin and Cotter Pin** - Remove the Cotter Pin and Stabilizer Lock Pin and fully extend each stabilizer.
 2. **Stabilizer Leg** - Align the Stabilizer Leg hole with the hole in the stabilizer support tube and reinstall the lock pins and cotter pins.
 3. **Stabilizer Jack** - Using the Stabilizer Jack Handle, rotate the handle clockwise to extend the jack screw until to make firm contact with the ground.
- **DO NOT** use the stabilizers to level the machine.
 - **DO NOT** raise the tires off the ground with the stabilizers.

Note

Repeat this procedure for each stabilizer.

To store the stabilizers, follow the above procedure in the opposite order.



Warning

Tip Over Hazard
Failure to read the following safety precautions could result in death or serious injury.

Important Note

Each stabilizer is electrically interlocked with a limit switch. The work platform has a 20 foot cutout lift function and **WILL NOT** lift to maximum height of 26 feet unless all four stabilizers are locked in place, and the stabilizer foot is making firm contact with the ground. The stabilizers **MUST** be fully retracted before driving.

2-29. Battery Service Procedures**Warning****Explosion Hazard**

Keep flames and sparks away. Do not smoke near batteries.

**Warning****Battery Acid Is Extremely Corrosive**

Wear proper eye and facial protection as well as appropriate protective clothing.
If contact occurs, immediately flush with cold water and seek medical attention.

Servicing The Batteries

1. Turn the Emergency Main Power Disconnect Switch to "OFF" position.
2. Check battery case for damage.
3. Check battery fluid level in each battery. If plates are not covered by at least 1/2" (13mm) of solution, add distilled or demineralized water.
4. Clean battery terminals and cable ends thoroughly with a terminal cleaning tool or wire brush.
5. Make sure all battery connections are tight.
6. Replace any battery that is damaged or incapable of holding a lasting charge.
7. Do not use any batteries other than flooded lead-acid batteries of the proper AH rating.

2-30. Battery Charging Procedures**EE-Rated Machines****Warning**

Do not charge batteries in hazardous area!
The EE-rating of a machine does not include the charging of batteries.

1. Move the aerial platform to an area designated for battery charging. (Refer to NFPA 505* for charging set-up.) *NFPA 505 is a publication of: **National Fire Protection Association, Inc.** Batterymarch Park, Quincy, MA 02269 (USA)
2. Connect battery charger DC plug into the battery plug at the rear of the base.
3. Charge batteries. (Refer to battery charger operation manual for procedures.) When charge cycle is completed, disconnect charger plug from battery tray.

Standard Machines

Warning
Explosion Hazard

Charges can ignite flammable materials and vapors. **DO NOT** use near fuels, grain dust, solvents or other flammables.

Warning
Shock Hazard

To reduce the risk of electrical shock, the charger must only be connected to properly grounded single phase outlet. The AC circuit protection should not exceed 15 amperes. The extension cord used **must** be a three wire grounded cord of at least 14 AWG. **DO NOT** use an extension cord longer than 25 feet (7.6m). Inspect AC charger's receptacle for the presence of water from washing or storage. Dry thoroughly prior to use.

1. Check for a firm AC connection at the charger receptacle. Connect the charger cord to the AC wall plug to turn the charger on. Refer to charger nameplate for voltage requirements.
2. Charge batteries. **DO NOT** leave charger unattended for more than two consecutive days. Severe overcharging and battery damage will result if charger fails to turn off.
3. Disconnect charger from external power source.

2-31-a. Battery Charger (If Equipped)



Figure 2-17. Bycan Battery Charger (SK2440E Shown)

Battery Status (SK 2440A/SK 2440E)

- 1. Green LED Complete
- 2. Yellow LED Check Battery
- 3. Red LED In Progress

Battery Status (SK 2440U)

- Red LED Charging
- Red/Yellow LED 80% Charged
- Green LED Complete
- Yellow LED Check Battery

Apply The AC power. The charger will start immediately (the transformer will hum and fan will come on). The red LED will come on. The ammeter will show charging current.

The current will be high for approximately 30 minutes then it will taper off. If the current does not taper off, disconnect the charger and check the batteries for a shorted cell.

When the battery bank voltage reaches approximately 30 volts DC, the yellow flashing LED will illuminate. This indicates that the charger has now entered a timed equalizing cycle. After completing the 3.5 hour cycle, the charger will shut off and the green LED will come on to indicate a complete charge.

If a shorted battery cell prevents the charger from raising the battery voltage to approximately 30 VDC to start the equalization timer, a second timer will shut down the charger after 16 hours of continuous charging. When this happens, the flashing yellow LED will come on to notify the user that the battery bank should be inspected for a shorted/damaged cell.

2-31-b. Battery Charger (If Equipped)



Figure 2-18. MAC Charger

If the “80% CHARGE” light continues to stay on after the charge cycle is complete, this indicates to the operator that the batteries are not capable of attaining a full charge.

If the “INCOMPLETE” light remains on after the charge cycle is complete, this indicates to the operator that the batteries are not capable of attaining even an 80% charge.

If either the “80% CHARGE” or “INCOMPLETE” light remain on after the charge cycle is complete, the batteries should be inspected for problems.

Refer to the “Battery Service” section for proper battery inspection and maintenance procedures.

Battery Status

- 1. GREEN L.E.D. CHARGE COMPLETE
- 2. YELLOW L.E.D. 80% CHARGE
- 3. RED L.E.D. INCOMPLETE

Charger Status

- 4. YELLOW L.E.D. CHARGER ON
- 5. RED L.E.D. ABNORMAL CYCLE

This charger is equipped with an electronic circuit that will completely recharge the batteries and automatically turn off after the charge cycle is complete.

The function of the L.E.D. indicators is as follows:

When the AC power is connected to the charger, the L.E.D.'s will flash several times then flash independently to check the light circuits. After the flashing sequence is complete the “INCOMPLETE” light will come on. Five seconds later, the “CHARGER ON” light will come on and at the same time, the ammeter will indicate how much current is going to the batteries.

As the charge cycle continues, which can last between 1 1/2 hours and 16 hours for a complete cycle, depending on the state of charge of the batteries, the “80%” light will come on and the “INCOMPLETE” light will go off. When voltage of the batteries reaches approximately 30 volts, the “80%” light will go off and the “CHARGE COMPLETE” light will come on. This light will remain on even after the charger is turned off by the electronic control. After the charger turns off, the “CHARGE COMPLETE” light will indicate to the operator that the batteries are fully charged.

2-31-c. Battery Charger (If Equipped)

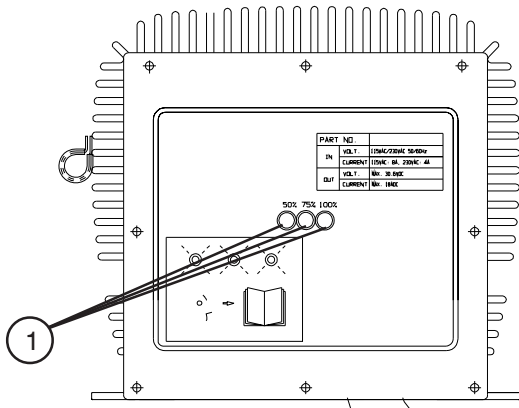

Figure 2-19. Battery Charger

Operation Of Charger



Danger

Risk of electric shock. Do not immerse the charger in water. Though the charger is highly resistant to water, it is not designed for immersion and an electric shock can occur.

1. Provide adequate ventilation for the batteries and charger. The convection cooled design requires access to cooling air for proper operation. Do not allow blankets or other materials to cover the charger. Though the charger protects itself against overheating, the charger cooling fins should be cleaned if clogged with debris for best performance.



Warning

There could be a spark during charging. Be careful when using fuels, solvents or other flammables near the charger or batteries.

2. Connect the power supply cord to a properly grounded 100V/50 or 60Hz, 115V/60Hz, or 230V/50 or 60Hz socket. This charger automatically senses and adjusts to the AC input voltage range.



Caution

When changing the input voltage wait until all the LED's are OFF or wait a minimum of 20 seconds before switching on the new voltage.

3. The charging time is affected by numerous factors including battery Amp-Hour capacity, depth of discharge, battery temperature, and battery condition (new, old, or defective). Batteries larger than 240 Ah can be recharged but will take longer.



Danger

Do not disconnect the DC output wires near the batteries when the charger is ON. The resulting arcing could cause the batteries to explode. If the charger must be disconnected, first disconnect the AC power supply cord from its outlet, then disconnect the charger DC connections.



Danger

Risk of an electric shock. Do not touch un-insulated parts of the charger output wires, battery connector, or battery terminals.



Danger

Visually and manually inspect to verify the DC output wires and terminals are in good working condition before each use.

4. The charger will start automatically within four to six seconds. The charger will start even with severely discharged batteries (down to 1V terminal voltage). Once charging starts, the LED's indicate the charging progress.

Charging State LED

State of charge	1 ST LED	2 ND LED	3 RD LED
0 to 50%	Blinking	Off	Off
50% to 75%	On	Blinking	Off
75% to 100%	On	On	Blinking
100%	On	On	On

60133AA

The charger goes into an equalizing charge mode after the batteries are charged and all 3 LEDs are "ON". The charger will continue to charge at a low current then shut-off automatically when complete. If all 3 LEDs blink together, there is a problem.

Take proper action according to the following instructions:

3 LEDs blink once simultaneously: Output connection error. Check the battery and charger connection. The output may not be connected to the batteries or the connections to the batteries may have corroded or loosened. The output may be shorted due to improper connection to the batteries or pinched wires. The output may be connected in reverse polarity to the batteries. The charger is not damaged by any of these problems.

3 LEDs blink twice simultaneously: The charger is indicating that the AC voltage is too low or too high. Check the AC input voltage.

3 LEDs blink three times simultaneously: Charger is overheated. No action required. When the charger cools, charging will restart automatically. Check and correct for dirt or other debris on charger that may be reducing cooling.

3 LEDs blink four times simultaneously: Input or output over current. No action required, charger will correct and restart automatically.

Batteries do not fully charge. If the batteries are charged overnight, make sure the AC supply is not being switched-off at night with other building items. Check battery condition and for dead cells or reduced capacity. Replace charger only if other problems are not found.

The AC line circuit breaker or fuse is blown. A defective circuit breaker or fuse, an overloaded circuit, or a charger problem can cause this condition. Try connecting the charger to a different AC outlet (on a different circuit) in the building. If the AC supply checks good, the charger should be replaced.

Table 2-1a. Specifications and Features

Model		3015	3219	3220	3226
Weight Ω		2200 lbs. (998 kg)	2430 lbs. (1102 kg)	3739 lbs. (1696 kg)	4660 lbs. (2114 kg)
Width		30" (0.76 m)	32" (0.81 m)		
Length		67.0" (1.7 m)	68.0" (1.73 m)	88.5" (2.24 m)	
Platform Size		28" x 64" (0.71 x 1.63 m)		28" x 81" (0.71 x 2.05 m)	
Height	Working	21' (6.4 m)	25' (7.6 m)	26' (7.92 m)	32' (9.75 m)
	Platform Elevated	15' (4.6 m)	19' (5.8 m)	20' (6.1 m)	26' (7.92 m)
	Platform Lowered	39.5" (1.00 m)	39.0" (0.99 m)	38.0" (0.97 m)	44.0" (1.12 m)
	Hinged Railing	N/A	N/A	81.75" (2.08 m)	87.0" (2.21 m)
	Fixed Railing	78.0" (1.98 m)	79.0" (2.01 m)	79.25" (2.01 m)	N/A
Drive Height	ANSI	Full	Full	Full	18' (5.5 m)
	CSA				
	CE				
High Travel Speed		2 mph (3.2 km/h)			
Elevated Drive Speed		0.65 mph (1.05 km/h)		0.64 mph (1 km/h)	0.66 mph (1.1 km/h)
High Torque Drive Speed		N/A		1.2 mph (1.9 km/h)	1.33 mph (2.14 km/h)
Lift time (No Load)		21 sec.	30 sec.	23 sec.	42 sec.
Lower Time (No Load)		29 sec.	40 sec.	40 sec.	39 sec.
Lift Time (Rated Load)		23 sec.	33 sec.	28 sec.	56 sec.
Lower Time (Rated Load)		19 sec.	29 sec.	27 sec.	30 sec.
Gradability		20% +		25%	
Tires		12 x 4 x 8		16 x 4 x 8	
		Solid Rubber			

60292AA

Ω Weight with standard 3' (0.9m) extension platform. Refer to Serial Nameplate for specific applications.

Table 2-1b. Specifications and Features

Model		4620	4626	4830	6826	6832
Weight Ω		3593 lb (1630 kg)	4198 lb (1904 kg)	5600 lb (2540 kg)	5020 lb (2277 kg)	5480 lb (2486 kg)
Width		46" (1.17 m)		48" (1.22 m)	68" (1.73 m)	
Length		88.25" (2.24 m)			99.25" (2.52 m)	
Platform Size		42" x 81" (1.07 x 2.05 m)			60" x 81" (1.53 x 2.05 m)	
Height	Working	26' (7.92 m)	32' (9.75 m)	36' (11.0 m)	32' (9.75 m)	38' (11.6 m)
	Platform Elevated	20' (6.1 m)	26' (7.92 m)	30' (9.14 m)	26' (7.92 m)	32' (9.75 m)
	Platform Lowered	38.0" (0.97 m)	45.0" (1.14 m)	49.5" (1.26 m)	51.25" (1.30 m)	55.75" (1.42 m)
	Hinged Railing	79.0" (2.01 m)	88.63" (2.25 m)	93.0" (2.36 m)	94.7" (2.41 m)	98.70" (2.51 m)
Drive Height	ANSI	Full	Full	26' (7.9 m)	Full	Full
	CSA					
	CE					26' (7.9 m)
High Travel Speed		2 mph (3.2 km/h)				
Elevated Drive Speed		0.67 mph (1 km/h)				0.4 mph (0.74 km/h)
High Torque Drive Speed		1 mph (1.6 km/h)				
Lift time (No Load)		35 sec.	44 sec.	55 sec.	45 sec.	55 sec.
Lower Time (No Load)		35 sec.	40 sec.	42 sec.	40 sec.	55 sec.
Lift Time (Rated Load)		36 sec.	58 sec.	64 sec.	55 sec.	60 sec.
Lower Time (Rated Load)		30 sec.	31 sec.	31 sec.	31 sec.	44 sec.
Gradability		25%				
Tires		16 x 4 x 8 Solid Rubber			23 x 10.5 x 12 Foam Filled	

60293AA

Ω Weight with standard 3' (0.9m) extension platform. Refer to Serial Nameplate for specific applications.

Table 2-2. Floor Loading Pressure

Models		TOTAL MACHINE WEIGHT		TOTAL MACHINE LOAD					
				WHEEL		LCP**		OUP**	
		lbs	kg	lbs	kg	psi	Kg/cm ²	psi	Kg/cm ²
3015	min*	2200	998	---	---	50	3.51	---	---
	max*			---	---			---	---
3219	min*	2430	1102	---	---	58	4.08	---	---
	max*			---	---			---	---
3220	min*	3739	2032	---	---	95	6.68	---	---
	max*			---	---			---	---
3226	min*	4660	2114	---	---	113	7.95	---	---
	max*			---	---			---	---
4620	min*	3593	1630	---	---	95	6.68	---	---
	max*			---	---			---	---
4626	min*	4198	1904	---	---	105	7.38	---	---
	max*			---	---			---	---
4830	min*	5600	2540	---	---	131	9.21	---	---
	max*			---	---			---	---
6826	min*	5020	2277	---	---	60	4.22	---	---
	max*			---	---			---	---
6832	min*	5480	2488	---	---	66	4.64	---	---
	max*			---	---			---	---

60294AA

* min - Total machine weight with no options

max - Machine weight + all options + full capacity

** LCP – Locally Concentrated Pressure is a measure of how hard the machine presses on the areas in direct contact with the floor. The floor covering (tile, carpet, etc.) must be able to withstand more than the indicated values above.

OUP – Overall Uniform Pressure is a measure of the average load the machine imparts on the whole surface directly underneath it. The structure of the operating surface (beams, etc.) must be able to withstand more than the indicated values above.

NOTE

The LCP or OUP that an individual surface can withstand varies from structure to structure and is generally determined by the engineer or architect for that particular structure.

Floor Loading Pressure

Local Concentrated Pressure (LCP):

Foot Print Area = Length x Width

$$\text{LCP} = \frac{\text{Weight of Machine} + \text{Capacity (Lbs)}}{\text{Foot Print Area} \times 4 \text{ (Tires)}}$$

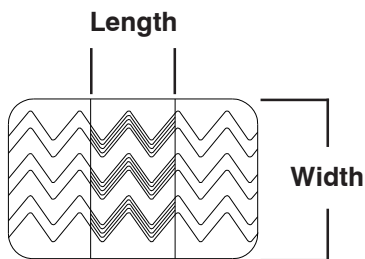
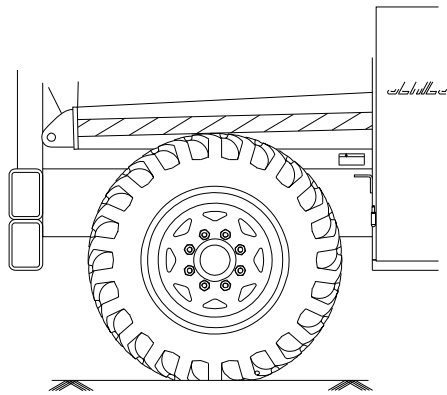

Overall Uniform Pressure (OUP):

Base Area = Length x Width

$$\text{OUP} = \frac{\text{Weight of Machine} + \text{Capacity}}{\text{Base Area}}$$

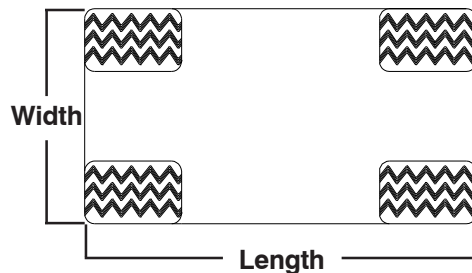
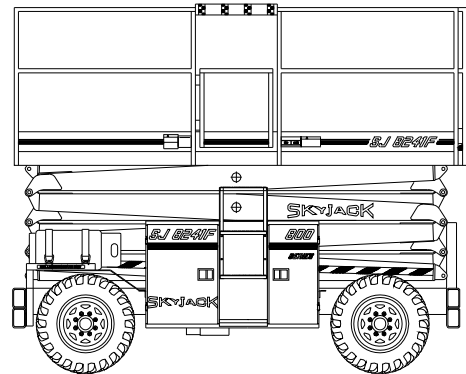

 **Warning**

Intermixing tires of different types or using tires of types other than those originally supplied with this equipment can adversely affect stability. Therefore, replace tires only with the exact original Skyjack-approved type. Failure to operate with matched approved tires in good condition may result in death or serious injury.

Section 2 - Tables

Table 2-3. Owner's Annual Inspection Record

Model Number _____				Serial Number _____				
Recording Date								
Recording Year #	1	2	3	4	5	6	7	8
Owner's Name								
Inspected By								

60141AA

As described earlier in this section, this decal is located on the scissor assembly. It must be completed after an annual inspection has been completed. Do not use the aerial platform if an inspection has not been recorded in the last 13 months.

Table 2-4. Maximum Platform Capacities (Evenly Distributed)

MODEL	With 3' Manual Extension Platform				With Powered Extension Platform			
	Main Platform		Extension Platform		Main Platform		Extension Platform	
3015	250 lbs (113kg)	1 Person	250 lbs (113kg)	1 Person	N/A	N/A	N/A	N/A
3219	250 lbs (113kg)	1 Person	250 lbs (113kg)	1 Person	N/A	N/A	N/A	N/A
3220	500 lbs (226 kg)	2 Person	300 lbs (136 kg)	1 Person	400 lbs (181 kg)	2 Person	300 lbs (136 kg)	1 Person
4620	800 lbs (362 kg)	2 Person	300 lbs (136 kg)	1 Person	700 lbs (317 kg)	2 Person	300 lbs (136 kg)	1 Person
4626	550 lbs (249 kg)	2 Person	300 lbs (136 kg)	1 Person	450 lbs (204 kg)	2 Person	300 lbs (136 kg)	1 Person
4830	400 lbs (181 kg)	2 Person	300 lbs (136 kg)	1 Person	N/A	N/A	N/A	N/A
6826	900 lbs (408 kg)	2 Person	300 lbs (136 kg)	1 Person	700 lbs (317 kg)	2 Person	300 lbs (136 kg)	1 Person
6832	700 lbs (317 kg)	2 Person	300 lbs (136 kg)	1 Person	700 lbs (317 kg)	2 Person	300 lbs (136 kg)	1 Person

60289AA

NOTE: Overall capacity - Occupants and materials not to exceed rated load.



Warning

This aerial platform is equipped with a Overload Sensing System. Do not exceed the rated capacity of the aerial platform. Failure to avoid this will prevent operation of all normal controls/functions of the aerial platform.

To resume normal operation remove the additional loads.

General Maintenance

Before attempting any repair work, disconnect the battery by turning the Battery Disconnect switches to the off position. Preventative maintenance is the easiest and least expensive type of maintenance.

Table 2-5. Maintenance and Inspection Schedule

	Daily	Weekly	Monthly	3 Months	6 Months	12 Months*
Mechanical						
Structural damage/welds	A					A
Parking brake	B					B
Tires/wheels & fasteners	A, B, C					A, B, C
Guides/ rollers & slider pads	A, B, I					A, B, I
Railings/Entry chains/gates	A, B, C					A, B, C
Bolts and fasteners	C					C
Maintenance Support	B					B
Rust			A			A
Wheel Bearings and King Pins	A, B, E					A, B, E
Steering cylinder & tie rod				A, B, E		A, B, E
Electrical						
Battery fluid level	A					A
Control switches/Indicator Lights	A, B					A, B
Cords & wiring	A					A
Battery terminals	A, C		A, C			A, C
Generator/receptacle	A, B					A, B
Terminal and Plugs	C					C
Limit Switches	B					B
Hydraulic						
Hydraulic oil	H					H
Hydraulic hoses/fittings	A, L		C			A, C, L
Lift/lowering speeds				G		G
Cylinders		A, B				A, B
Emergency lowering	B					B
Lift capacity			D			D
Hydraulic oil & oil filter					F	F
Miscellaneous						
Labels & Manual	A, J, K					A, J, K
Notes						
A. Visually inspect. B. Check operation. C. Check tightness. D. Check relief valve setting. Refer to serial number nameplate E. Lubricate. F. Replace. G. Refer to Table 2-1 specifications and features.			H. Check oil level. I. Insure there is no metal to metal contact with slider, slider side or running surface. Check for free movement of surface. Also check for free movement of the pin through the slider. J. Replace if missing or illegible. K. Proper manual must be in box L. Check for leaks. * Record inspection date and signature			

60296AA



Warning

Use original or equivalent to the original parts and components for the aerial platform.

Labels And Nameplates Models 3015 & 3219

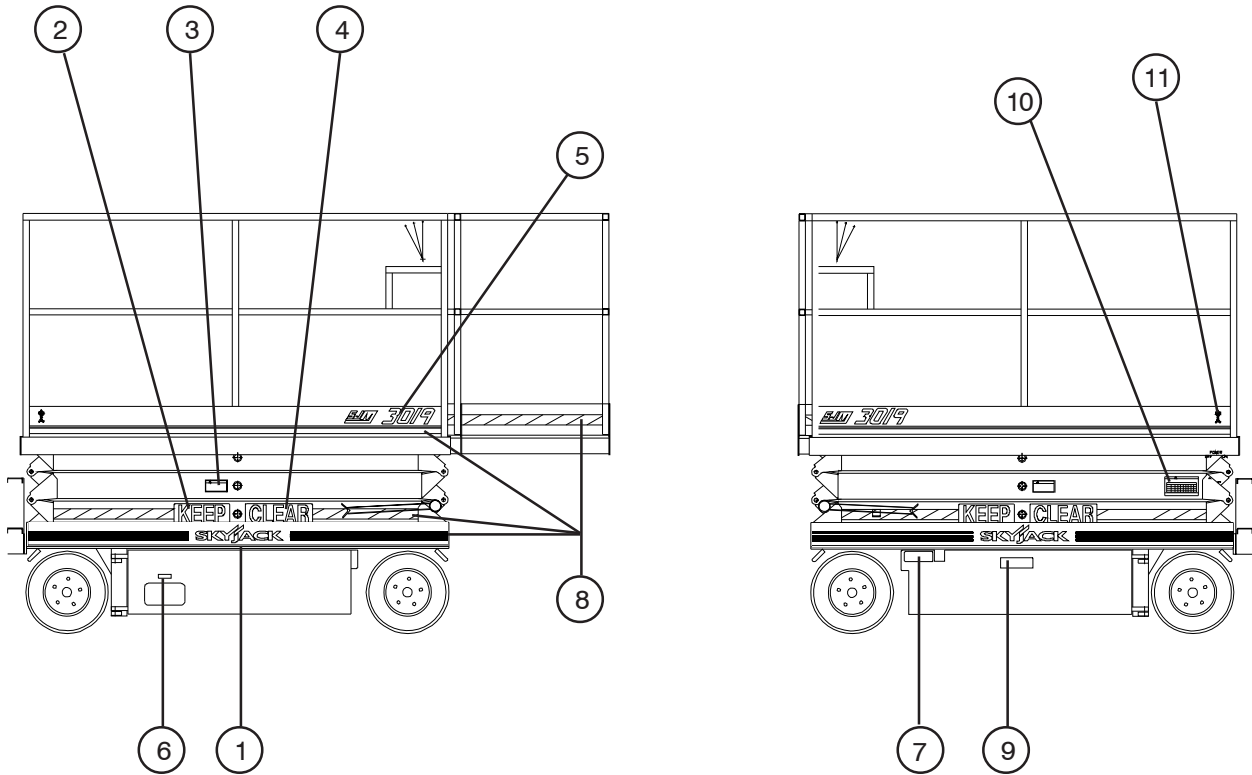

- 1 LABEL, Skyjack Small, Blue
- 2 LABEL, Keep
- 3 LABEL, Caution Lift
- 4 LABEL, Clear
- 5 LABEL, Model Designation sjll-sides.plt
- 6 LABEL, Battery Charger Connection

- 7 LABEL, Emergency Lowering
- 8 LABEL, Tape Assembly
- 9 LABEL, Emergency Battery Disconnect Switch
- 10 LABEL, Annual Inspection
- 11 LABEL, Skyjack Logo

10994AA

Labels And Nameplates 3015 & 3219

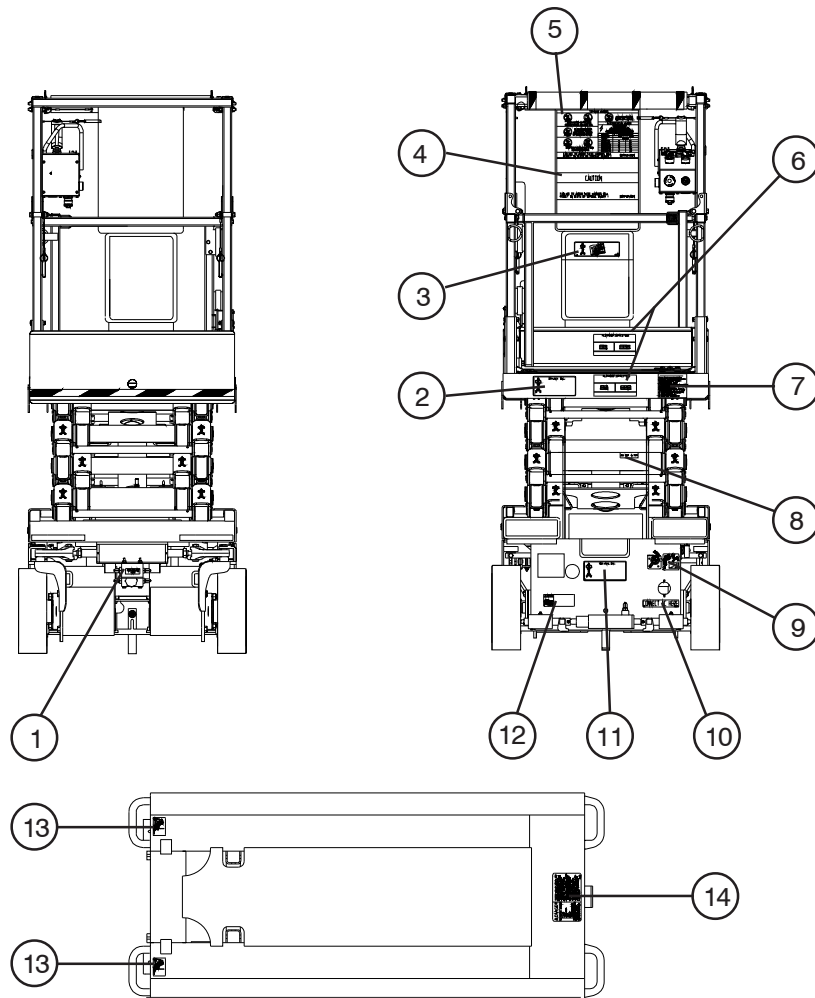

- 1 LABEL, Free Wheeling Valve
- 2 LABEL, On/Off Slab
- 3 LABEL, Manual
- 4 LABEL, Caution
- 5 LABEL, Danger
- 6 LABEL, Platform Capacities
- 7 LABEL, Checklist

- 8 LABEL, Do Not Alter
- 9 LABEL, Emergency Main Power Disconnect
- 10 LABEL, Connect AC Supply
- 11 LABEL, Caution, Brake
- 12 LABEL, NAMEPLATE, Serial Number
- 13 LABEL, Forklift Boot
- 14 LABEL, Safety Bar

10999AB

Labels And Nameplates Models 3015 & 3219

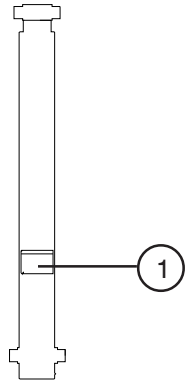

LIFT CYLINDER

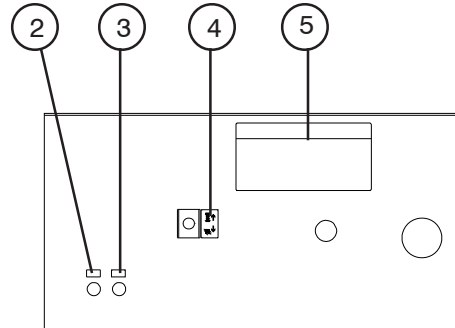

ELECTRICAL PANEL

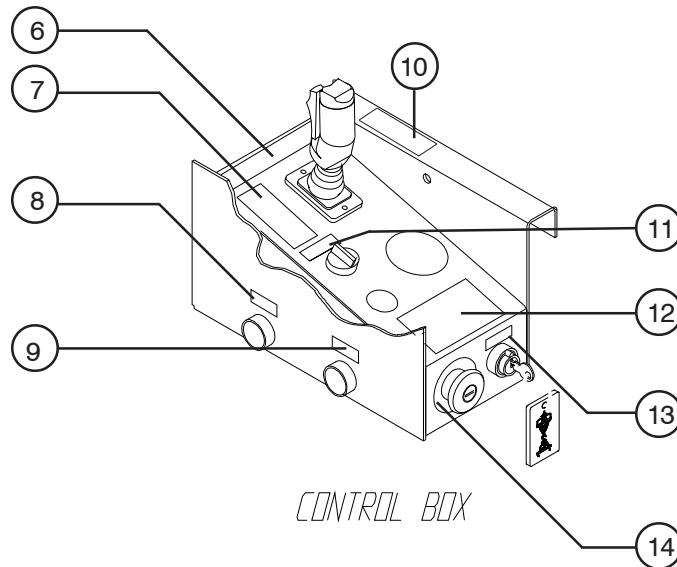

CONTROL BOX

- | | | | |
|---|------------------------------------|----|--------------------------------------|
| 1 | LABEL, Orifice | 8 | LABEL, Horn |
| 2 | LABEL, Ground Reset | 9 | LABEL, Lift Enable |
| 3 | LABEL, Power Reset | 10 | LABEL, Enable Joystick (If Equipped) |
| 4 | LABEL, Up/Down Switch | 11 | LABEL, Up/Down Switch |
| 5 | LABEL, Warning Replacement Parts | 12 | LABEL, Operator Warning |
| 6 | LABEL, Operations | 13 | LABEL, Power Off/On |
| 7 | LABEL, Controller, Forward/Reverse | 14 | LABEL, Emergency Stop |

10992AB

Labels And Nameplates Models 32XX, 46XX, 4830 & 68XX

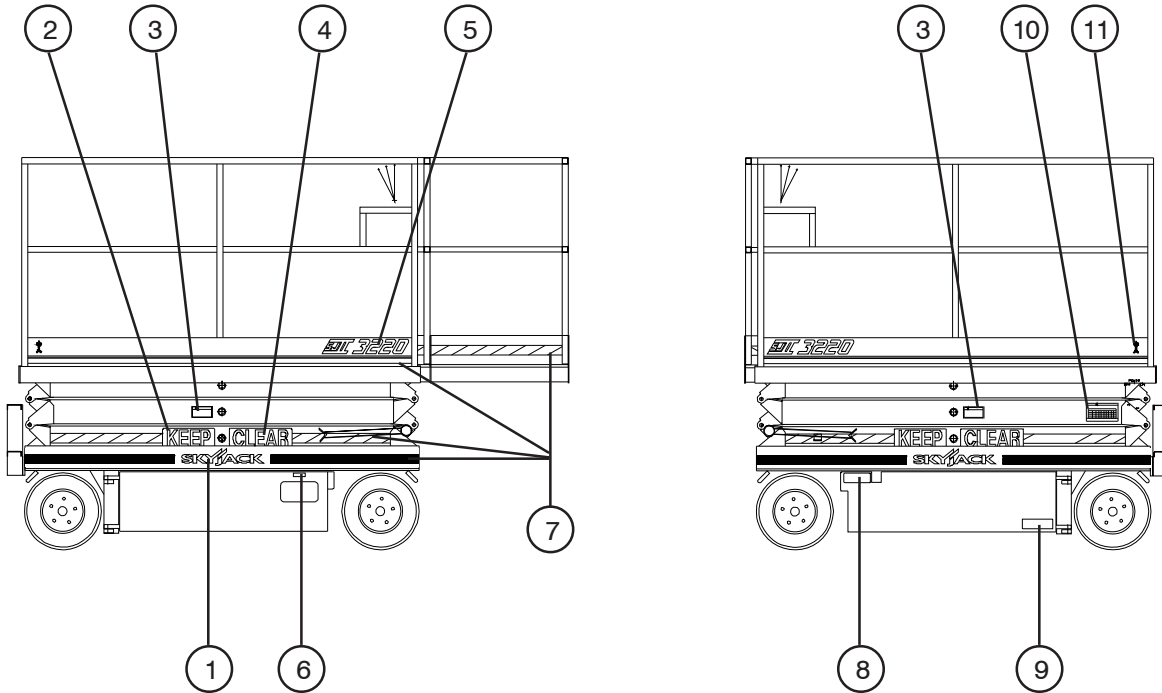

- 1 LABEL, Skyjack Small, Blue
- 2 LABEL, Keep
- 3 LABEL, Caution Lift
- 4 LABEL, Clear
- 5 LABEL, Model Designation
- 6 LABEL, Battery Charger Connection

- 7 LABEL, Tape Assembly
- 8 LABEL, Emergency Lowering
- 9 LABEL, **Emergency Battery Disconnect Switch**
- 10 LABEL, Annual Inspection
- 11 LABEL, Skyjack Logo

10998AA

Labels And Nameplates Models 32XX, 46XX, 4830 & 68XX

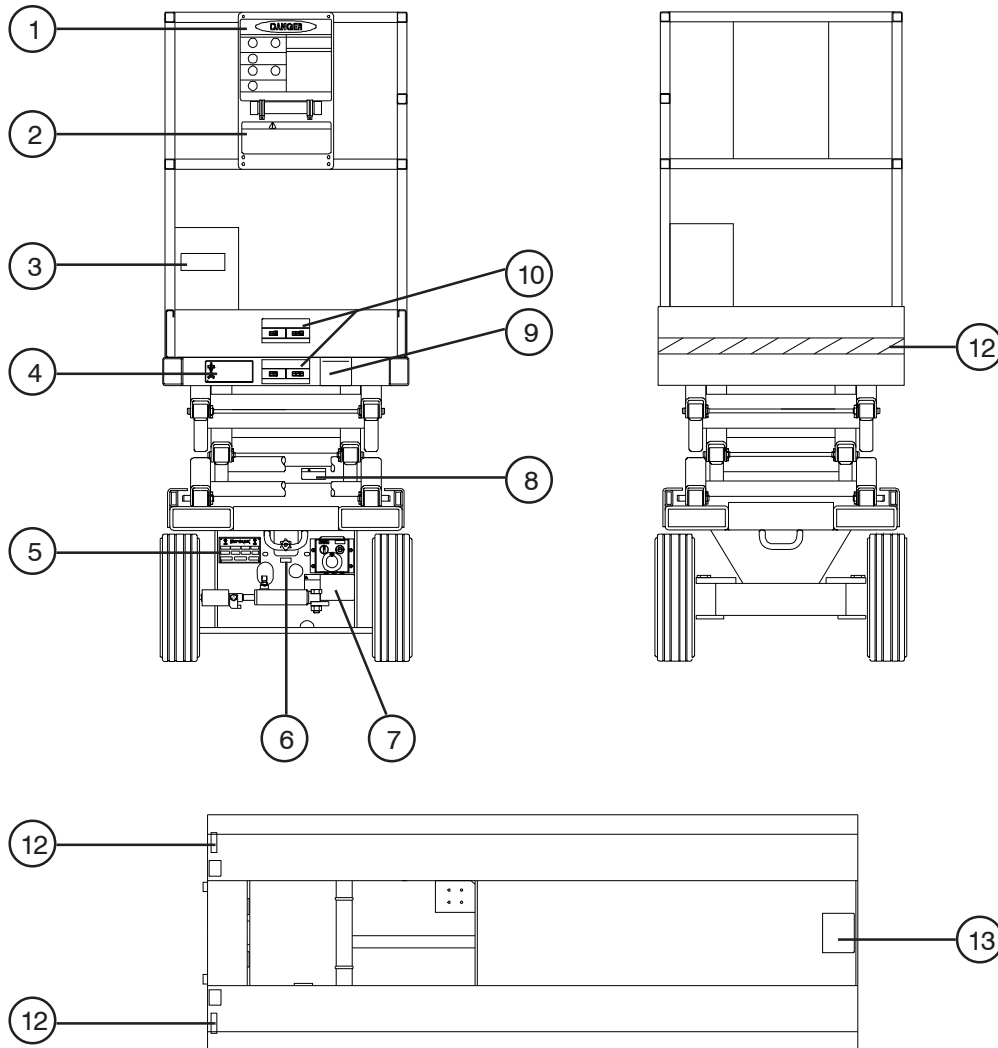

- | | | | |
|---|----------------------------|----|----------------------------|
| 1 | LABEL, Danger | 8 | LABEL, Do Not Alter |
| 2 | LABEL, Caution | 9 | LABEL, Checklist |
| 3 | LABEL, Manual | 10 | LABEL, Platform Capacities |
| 4 | LABEL, On/Off Slab | 11 | LABEL, Tape Assembly |
| 5 | NAMEPLATE, Serial Number | 12 | LABEL, Forklift Boot |
| 6 | LABEL, Free Wheeling Valve | 13 | LABEL, Safety Bar |
| 7 | LABEL, Caution Brake | | |

20007AA

Labels And Nameplates Models 32XX, 46XX, 4830 & 68XX

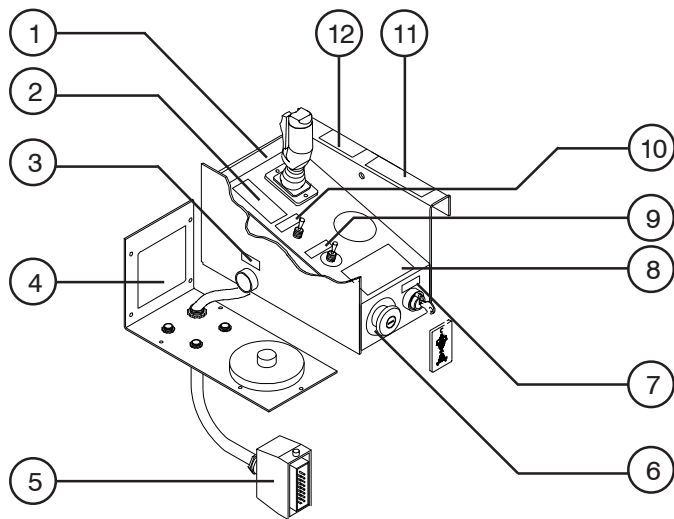

CONTROL BOX

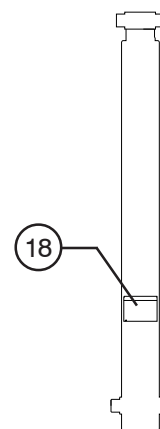

LIFT CYLINDER

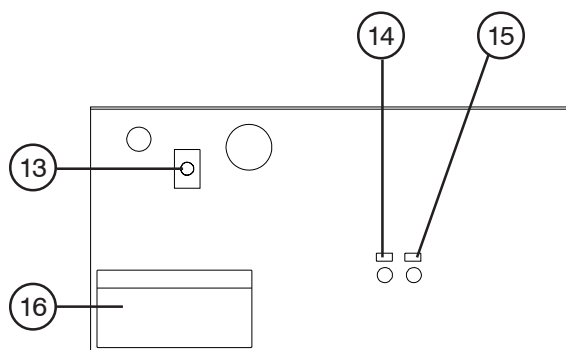

ELECTRICAL PANEL

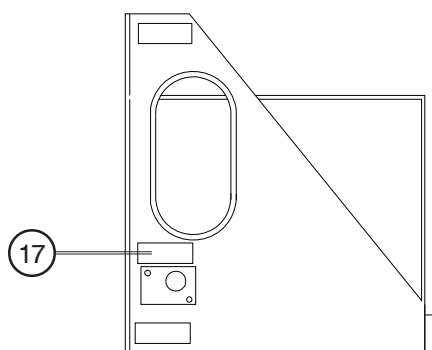

ELECTRICAL PANEL

- | | | | |
|---|--|----|--|
| 1 | LABEL, Operations | 10 | LABEL, High/Low Torque |
| 2 | LABEL, Controller, Lift/Drive | 11 | LABEL, Falling Hazard (If Equipped) |
| 3 | LABEL, Horn | 12 | LABEL, Enable Joystick |
| 4 | LABEL, Joystick Connector | 13 | LABEL, Up/Down |
| 5 | LABEL, Hydraulic Proportional (If Equipped) | 14 | LABEL, Ground Reset |
| 6 | LABEL, Emergency Stop | 15 | LABEL, Power Reset |
| 7 | LABEL, Power Off/On | 16 | LABEL, Warning Replacement Parts |
| 8 | LABEL, Operator Warning | 17 | LABEL, Emergency Disconnection Switch |
| 9 | LABEL, Lift/Off/Drive Switch | 18 | LABEL, Orifice |

10991AA



MOBILE ELEVATING PLATFORMS

www.skyjackinc.com